

Connecting Distributed Energy Resources



Revision: #7.3, May 2026

Halton Hills Hydro Inc.
43 Alice Street
Acton, Ontario
L7J 2A9

Phone: (519) 853-3700
(905) 453-2222
Fax: (519) 853-5168

www.haltonhillshydro.com



Connecting Distributed Energy Resources

This document has been developed to provide those seeking to interconnect distributed energy resources to Halton Hills Hydro's distribution system with specific information, requirements, and the process for connection.

Table of Contents

Connecting Distributed Energy Resources	1
Table of Contents	2
Introduction	4
Revisions	5
Net Metering Program.....	6
What is Net metering?.....	6
What type of generation can I use?	6
What’s the process to connect to HHH’s Distribution System?.....	6
Agreements for Net Metering	6
Technical	6
Metering	7
Connection Costs	7
How will my bill be calculated?.....	7
What do I need to do to get started?	7
What if I want to sell generated power to the distribution system?	7
Can I use my own power during an outage?	8
Connection Process Flowchart	9
Connection Process Overview.....	10
Initial Consultation	10
Connection Impact Assessment.....	10
Connection Cost Estimate	10
Design and Build.....	10
Connect, Operate and Maintain	10
The Ontario Electricity Transmission & Distribution System	11
Distinctions Between Types of Distributed Energy Resources	12
Safety, Power Quality & Protection	13
Safety	13
Islanding	13

Grounding	14
Power Quality	14
Voltage Fluctuations and Voltage Regulation	14
Voltage Unbalance	15
Frequency	15
Harmonics	15
Power Factor	15
DC injection	16
Voltage Flicker	16
Protection of A distributed energy resource Facility	16
Isolating Device	17
Monitoring and Recording	18
Remote Access, Control, and Telecommunications	19
Requirements by Generation Size.....	20
Standardized or Certified Equipment.....	22
Preliminary Review, Technical Review, Impact Assessment	24
Generation Connection Process	24
Preliminary Review	24
Technical Review	24
LDC Impact Assessment	25
Hydro One Impact Assessment	26
Costs	26
Production and Commissioning Tests	27
Termination of Process (Prior to Connection)	27
Metering	28
Approvals	29
Protection Philosophy Requirements.....	30
Appendices	32

Introduction

The mission of Halton Hills Hydro as a Local Distribution Company (LDC) is to provide Halton Hills with a high level of service reliability and distribution excellence in a safe and reliable manner.

Halton Hills Hydro is committed to providing information, advice and direction to Generators who wish to connect a distributed energy resource to HHH's electricity distribution system.

This guide contains an overview of the Ontario electricity transmission system, typical LDC Hydro distribution systems and safety, power quality, protection and other technical issues related to new generation.

This guide has two goals:

- To provide the technical requirements of connecting distributed energy resources to HHH's distribution system
- To outline the necessary administrative procedures

Distributed energy resources are any type of electrical generator or static inverter producing alternating current that has the capability of Parallel Operation with the LDC distribution system, or is designed to operate separately from the LDC system and can supply a load that can also be fed by the LDC distribution system.

Although some distributed energy resources are intended to provide electricity solely for a customer's own use, non-exporting generation, this guide also covers the emerging role of a distributed energy resource in supplying Ontario's generation needs through the sale of some or all the electricity generated by exporting it through the LDC's electricity distribution system.

Distributed energy resource also varies in design and fuels from diesel or natural gas standby generators to natural gas co-generation to wind turbines, photo voltaic cells, bio gas and hydro-electric generation. A further variable is size, from very small (micro) wind and photo voltaic units in the under 12 kilowatt (kW) range to generation in the multi megawatt (MW) range.

Due to the variability, size and complexity of each generation project, this guide provides only general information on connecting to HHH's distribution system. In this introductory guide we have kept the content at a fairly high-level, providing references to enable access to more specific details. We have used plain language and simple examples to illustrate the points.

Should there be conflicts or contradictions between the simplified examples in this guide and specific information, the specific information will take precedence.

Revisions

Revision No.	Description
6.1	<ul style="list-style-type: none"> Revised power quality and monitoring limits based on nameplate rating size. Added fields for nameplate rating in kW and under frequency protection settings to Generator Connection Assessment Review Form, 12kW or Less (Appendix 3). Assessment Review form now revision 4. Added field for nameplate rating in kW to Generator Connection Assessment Review Form, 12kW to 10MW (Appendix 4). Assessment Review form now revision 4.
6.2	<ul style="list-style-type: none"> Updates to Commissioning and Equipment Verification Report (Appendix 7), now R1, August 2011.
6.3	<ul style="list-style-type: none"> Updates to document reflecting microFIT V2.0 and FIT V2.0 rules. Updates to internet addresses.
6.4	<ul style="list-style-type: none"> Updated micro-embedded connection agreement.
6.5	<ul style="list-style-type: none"> Changed references of Ontario Power Authority (OPA) to Independent Electricity System Operator (IESO).
7.0	<ul style="list-style-type: none"> Changes title to Connecting Distributed Energy Resources. Updated ESA Micro-Embedded Generation Guidelines in Appendix 5. Added Protection Philosophy. Updated Connection Review Application Form in appendix 2.
7.1	<ul style="list-style-type: none"> Updated Connection Impact Assessment Application (Appendix 4).
7.2	<ul style="list-style-type: none"> Updated Appendix 2. Removed Connection Review Application Form and added Preliminary Consultation Information Request (PCIR) Form.
7.3	<ul style="list-style-type: none"> Alignment with DSC amendments, increased the maximum nameplate capacity for micro-embedded generation facilities from 10kW to 12kW Removed Reference to load displacement. Updated CIA timeline for small, embedded generation facilities requiring assessments by host distributors. DERCP V 2.0

Net Metering Program

With the rising costs energy, you may have thought about reducing your electricity costs by generating your own electricity. If so, Halton Hills Hydro's (HHH) Net metering program might be for you. The following outlines our Net Metering program for generation of 500kW or less and shows you in general the steps involved.

What is Net metering?

- Net metering measures the consumption of electricity you use against the amount of electricity you generate resulting in a "net" total from which your bill is calculated.
- Net Metering is ideal for those looking to reduce electricity costs.
- Under our Net Metering Agreement, excess generation credits can be carried forward up to twelve months to offset future electricity costs.

What type of generation can I use?

To qualify for our Net metering program, the type of generation must come from a Renewable Energy Technologies (RET), which are derived from natural resources that for practical purposes cannot be depleted. Any combination of wind, water, solar radiation or agricultural biomass with a total nameplate rating of 500 kW or less qualifies as an RET.

What's the process to connect to HHH's Distribution System?

- HHH recommends that all generator equipment be certified by the Canadian Standards Association (CSA). If it isn't, equipment must be site certified by the ESA.
- Installation of all generation facilities must be approved by the ESA and Connection Authorization provided to HHH prior to connection.
- To comply with Section 84 of the Ontario Electrical Safety Code, you are required to have an isolation switch (visible, accessible and lockable) located between the meter and your equipment.

Agreements for Net Metering

- Our Connection Review Application Forms (Appendices 2, 3, and 4 as applicable)
- Net metering applicants will need to enter into and comply with a Connection Agreement with Halton Hills Hydro Inc. (Appendix 8). The type of Connection Agreement will be based on the output capacity of the installed generation.

Technical

- Generator Protective Relay settings must be set as per the tables in the Agreement.
- Halton Hills may choose to perform a Connection Impact Assessment at your expense.

Metering

In order to bill you on a net metering basis and comply with the requirements of Measurement Canada, meter replacement is required. You will be responsible for costs associated with HHH upgrading the meter for your installation.

Your generator of less than or equal to 500kW:

Halton Hills Hydro will install a dual register meter capable of measuring your consumption from Halton Hills Hydro's distribution system and the amount of generation you supply into Halton Hills Hydro's distribution system. Credit for electricity generated will be incorporated into your regular bills. Halton Hills Hydro will determine meter reading frequency and method.

Connection Costs

You will be responsible for the costs of any modifications to Halton Hills Hydro's distribution system, including transformer changes needed to connect your generation facility.

How will my bill be calculated?

HHH will continue to read your meter as we do now. The bill you see will reflect the difference between the value of the electricity you return to the grid and the value of electricity you consume from the grid. If your net consumption for a billing period is zero, or results in a credit, the delivery portion of your bill will not include kilowatt-hour based charges and the net credit will be carried forward to the next billing cycle.

What do I need to do to get started?

When you call, make sure you have the following information ready:

- Your Halton Hills Hydro account number
- Service address (location of generator: lot/ concession/ township/ street address)
- Size of generator (kW)
- Type of generator (must be an RET)
- Planned in service date
- Fax number and/ or email address
- Contact our Customer Service or Engineering Departments at (519) 853-3700, Monday to Friday from 7:30 a.m. to 4:00 p.m. or by email at generation@haltonhillshydro.com.

What if I want to sell generated power to the distribution system?

Halton Hills Hydro will purchase power generated by you; however, you will be required to enter into a different connection process not covered by our Net metering program. General requirements for this application require you to:

- Review the information provided to you in the following pages of this guideline.
- Contact Halton Hills Hydro to inform us of your proposed project.
- Meet with Halton Hills Hydro personnel to discuss the project.
- Enter into a Connection Agreement and undergo a Connection Impact Assessment if required.
- Obtain a Generators License from the Ontario Energy Board (OEB).
- Purchase and install a distribution transformer.
- Purchase and install a four-quadrant interval meter acceptable to Halton Hills Hydro or pay Halton Hills Hydro for this service.
- The installation must conform to Halton Hills Hydro's Conditions of Service and meet the requirements of Halton Hills Hydro and the Electrical Safety Authority (ESA).
- Commissioning of installation witnessed by Halton Hills Hydro personnel and ESA.
- Contact the Independent Electricity System Operator (IESO) if you wish to take part in their Feed in Tariff Program.

Can I use my own power during an outage?

If you wish to run your generator during a Halton Hills Hydro power outage, your generator must have special transfer and isolating capabilities installed to ensure your generation facility cannot feed into Halton Hills Hydro's distribution system during an outage.

DER Connection Process Flowchart

Connection Procedures Overview

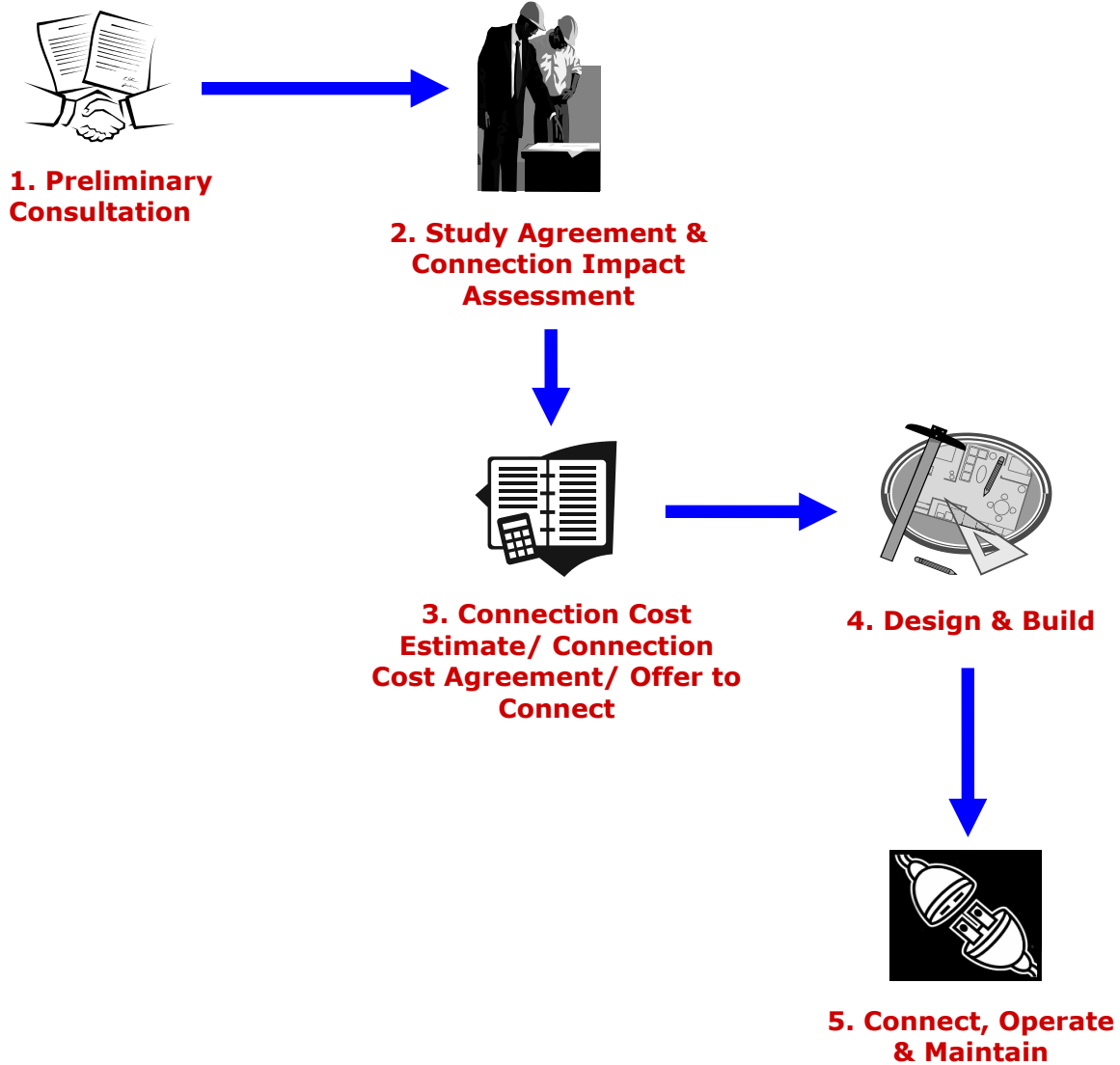

The process that HHH will follow for connecting a distributed generator to HHH's distribution system is detailed in the Ontario Energy Board's (OEB) Distribution System Code, Appendix F. (<http://www.oeb.gov.on.ca>)

Connection Process Overview

Initial Consultation

Halton Hills Hydro meets with the prospective Generator to discuss their plans, provide preliminary information on the connection options and explain the connection process. The Generator is required to complete and submit the DER Preliminary Consultation Information Request (PCIR) Form (Appendix 2) and provide other supporting documents to Halton Hills Hydro's Engineering Department.

Connection Impact Assessment

After reviewing the DER Preliminary Consultation Information Request Form and other technical data submitted during the initial consultation, the project will then be discussed with the Generator in a face-to-face meeting. The aim of this meeting is to discuss issues of mutual interest early in the Generator's review of the feasibility of the project. The Generator is then required to submit a completed Generator Connection Assessment Review Form. (Appendix 3 for a generator of 12kW or less or Appendix 4 for a generator rated at between 12kW to 10MW). Where applicable, the Generator is required to submit a Study Agreement (Appendix 9) with payment to enact the Connection Impact Assessment.

Connection Cost Estimate

After all, required assessments are complete (including assessment by Hydro One, if required), the scope of work required to connect new generation can be developed and estimates prepared. The Generator is required to make the appropriate payment to Halton Hills Hydro that could include fees for: processing and reviewing the application; technical review and impact assessment; and production and commissioning testing as necessary.

Design and Build

Once agreement of the scope, cost and timing are reached, the Generator is required to sign a Connection Cost Recovery Agreement. After submitting the agreement and payment, detailed design and construction may begin.

Connect, Operate and Maintain

After all of the required work and approvals are completed, Halton Hills Hydro and the Generator execute the Distribution Connection Agreement (Appendix 8). This Agreement provides an outline of the connection as well as the roles and responsibilities of each party.

The Ontario Electricity Transmission & Distribution System

In general, Ontario's electricity system consists of large centrally located generating stations linked by high voltage transmission lines over long distances at 500 kV, 230 kV and 115 kV. As the electricity is moved around the province the voltage is reduced as the electricity gets closer to the point of end use. Transformer stations reduce the voltage to 27.6 kV and 44 kV lines which transfer the electricity to distribution stations that reduce voltage again down to as low as 4 kV for routing electricity around streets.

It is likely that the location for a distributed energy resource will be at the lower voltage levels and the ability of the distribution network to accommodate the distributed energy resource will depend on the "strength" of the network at that point and the normal loads that it supplies. Another name for the "strength" of the network is the "fault current".

The fault current is the amount of current that will flow when there is a fault on a network. The fault level at the end of a long electricity circuit is much lower than closer to the upstream supply. At a low fault level site, the impact of the distributed energy resource can be great enough to disturb other local consumers. For this reason, it is sometimes necessary to reinforce the network, or connect the distributed energy resource to a higher voltage or stronger part of the network further away.

Higher-voltage systems such as the 230 kV or 500 kV transmission systems have high fault levels. In general, the lower the voltage, the weaker the system. The weaker the system the less distributed energy resources can be connected. Halton Hills Hydro's distribution system operates at 27.6 kV, 44 kV, 8.32kV, 4.16kV. As a general rule the voltage levels might have capacity for the maximum following amounts of distributed energy resources.

- 4.16/ 2.4 kV possibly between 500 kW and 1 MW
- 8.32/ 4.8 kV possibly between 500 kW and 1 MW
- 27.6/ 16.0 kV possibly between 1 MW and 10 MW
- 44 kV possibly between 5 MW and 10 MW

The above examples assume the presence of single-phase and where required three-phase lines with adequate conductor size and inherent load levels. The actual capacity of the lines to accept distributed energy resources can only be determined by an engineering review.

The necessary protection systems to protect Halton Hills Hydro's distribution system from events that can occur with distributed energy resources connected will also vary by generation size and distribution line characteristics. Therefore, similar units connected at different locations could have different protection requirements based on varying load conditions, as well as on HHH's Hydro One feeder supply and transformer characteristics.

Depending on the size, type, fuel, and location of generation facilities, the Ministry of the Environment (MOE) may require that the customer carry out an environmental assessment. Please contact the MOE for more information.

Distinctions between Types of Distributed Energy Resources

There are a number of distinct types of generators as far as the distribution system is concerned, these include: (a) solid-state or static inverters, (b) induction machines, and (c) synchronous machines.

Many smaller renewable energy systems produce grid quality AC power through an inverter and are therefore typically grouped together.

Induction and synchronous generators, on the other hand, are generally grouped together as “rotating machines,” but their different configurations do give them different start-up and operational characteristics. For example, induction machines cannot operate in standalone mode and generally require the presence of the grid for rotor excitation and normally have a lagging power factor. Synchronous machines on the other hand can operate without the grid and can have a zero or leading power factor.

As a practical matter, it is much more difficult for inverter-based generators to power an island and inverters can feed far less current into a fault. This means that inverter-based and rotating generators are treated differently in the codes and standards, with very small inverter-based devices requiring little – if any – additional protection equipment.

Battery Energy Storage Systems (BESS) allows a Generator to stored energy in batteries and distributed that stored energy into their facility during peak energy pricing times to off-set electricity costs. BESS systems can use solid state devices such as inverters to transform stored energy (DC) into usable energy (AC). While a BESS system does not generate electricity as do traditional distributed generation sources such as solar PV, wind, or hydro-electric, the stored energy is injected into the facility in a similar manner and thus has the potential to impact the safe operation of the distribution system. As such, BESS projects undergo the same process as would any other energy source that is interconnected to Halton Hills Hydro’s distribution system.

Safety, Power Quality & Protection

As part of the interconnection process, safety, power quality, and system reliability are the primary utility concerns and responsibilities. Reference materials that determine the requirements for these interconnections have been prepared by a number of bodies and agencies including the OEB, IEEE, CSA and ESA. This section therefore addresses safety and technical issues in the abstract and how to streamline the interconnection process. The purpose of this section is to provide background and rationale, without going into great technical detail.

The OEB's Distribution System Code (DSC) Appendix F.2, CSA C22.3 No. 9-08 "Interconnection of Distributed Resources and Electricity Supply Systems", and IEEE 1547 "Standard for Interconnecting of Distributed Resources with Electric Supply Systems" outlines the technical requirements for connecting a generator to an electricity distributor's system. We have identified specific sections of Appendix F.2 as they relate to safety, power quality and protection.

The link to the OEB DSC is at <http://www.oeb.gov.on.ca>

Safety

Like any source of electricity, distributed energy resources systems have the potential to be dangerous to both people and property, and require protection devices to protect the distribution system, utility workers, utility customers and the general public. Large industrial customers have been generating power on-site for many years, but interconnecting photo voltaic, wind turbines, co-generation, micro-turbines, and other relatively small generation systems to operate in parallel with the grid at residential and commercial locations is an increasing recent trend. Utilities are concerned with generators supplying energy to one of their lines that is otherwise thought to be de-energized. This is known as islanding.

Islanding

One of the most important issues for distributed energy resources is to avoid a condition known as islanding. Islanding is a situation where a portion of the utility system that contains both loads and a distributed energy resource source becomes separated from the remainder of the utility system but remains energized.

The primary concern is a situation where a fault occurs on the distribution system and automatic isolation of a utility protective device occurs. Since automatic reclosing is normally used on distribution systems to clear temporary faults it is essential that the distributed energy resource disconnects from the distribution system before the first automatic reclose occurs. The concern is that if the distributed energy resource does not disconnect fast enough: a) the distributed energy resource may feed the fault; and b) when the utility protective device(s) tries to reclose, it will be closing back in on a line

that is being supplied by a distributed energy resource resulting in possible equipment damage, overloading or power quality issues.

Historically with central generation and transmission an LDC could be sure that if an electrical circuit was isolated “upstream” and was not being fed from an alternative source that it was de-energized.

Halton Hills Hydro may want to isolate the section of line for maintenance purposes and would normally do that through opening switches. While a utility can be sure that all of its own electricity sources are either shut down or isolated from the area that needs work, we must now factor in a distributed energy resource to ensure that it too is isolated and not supplying the line section.

A distributed energy resource creates a source of energy inputs to the utility system that Halton Hills Hydro does not control. If the distributed energy resource is potentially capable of islanding it can backfeed electricity onto distribution system creating potential hazards to the system and those working on it. As such, at this time, all distributed energy resources must have **automatic** anti-islanding capabilities so as to disconnect the generation source from the utility system in the event of a utility outage.

Grounding

Distributed generators must be grounded in accordance with equipment manufacturers, the OESC and HHH requirements.

The distributed energy resource must not disrupt any coordination of ground fault protection or cause over-voltages that exceed the rating of equipment connected to HHH’s distribution system.

Power Quality

Power quality is another significant technical concern for utilities and customer-generators. Utility power is consistently supplied at a standard voltage and frequency. In North America, residences receive single-phase alternating current (AC) power at 120/240 Volts at 60 cycles per second (60 Hz), and commercial buildings typically receive either 120/240 Volts single phase or three-phase power depending on the size of the building and the types of loads in the building.

Power quality is important because electronic devices and appliances have been designed to receive power at or near rated voltage and frequency standards and deviations may cause equipment and appliance malfunction or damage. Additional power quality considerations include harmonics, power factor, DC injection, and voltage flicker.

Each type of distributed energy resource device has its own output characteristics based on its technology therefore some will have more power quality issues than others.

Voltage Fluctuations and Voltage Regulation

Voltage fluctuations can result from a distributed generator connecting to or disconnecting from the utility system or because of its generation operating

characteristics. The standards set certain limits which must be achieved for events that occur within the distributed energy resource's operating cycle. Whether the utility actively or passively regulates their voltages to maintain an acceptable range, the presence of a distributed energy resource should have no detrimental impact on that regulation. The distributed energy resource must not try to regulate the voltage and frequency on the utility line but instead must follow the utility voltage and frequency and disconnect for any abnormality.

Over and under voltage protection is required for all generation facilities. The voltage produced by any generator shall not deviate outside of the limits defined in CSA CAN3-C235-83 "Preferred Voltage Levels for AC Systems, 0 to 50,000V". Where the voltage deviates outside the limits the generation facility shall automatically disconnect itself from the distribution system. The Generators interconnection system shall include a reconnection delay of 5 minutes, minimum, after steady state voltage and frequency is restored before the generation reconnects.

Ref: OEB DSC, Appendix F.2, Section 3, 6, and 6.5

Voltage Unbalance

Utilities try to operate their three phase lines with voltages in the three phases balanced as closely as possible. The presence of a distributed generator should not contribute to additional voltage unbalance.

Ref: OEB DSC, Appendix F.2, Section 3.2

Frequency

As with voltage fluctuations frequency variations are a reliability and power quality issue. A distributed energy resource shall operate within the range of 59.3 to 60.5 Hz. Where the frequency deviates outside this range the generation facility shall disconnect itself. The Generators interconnection system shall include a reconnection delay of 5 minutes, minimum, after steady state voltage and frequency is restored before the generation reconnects.

Ref: OEB DSC, Appendix F.2, Section 6 and 6.5

Harmonics

Harmonics generically refer to distortions in the voltage and current waveforms caused by the overlapping of the standard sinusoidal waveforms at 60 hertz (Hz) with waves at other frequencies that are other multiples of 60 Hz. Harmonics can be caused by the electronic equipment used in some distributed generators such as soft start units and inverters. Harmonics can cause equipment to fail or overheat and to degrade the service of other customers. Distributed generators must not impose harmonic distortions on Halton Hills Hydro's distribution system in excess of applicable standards.

Ref: OEB DSC, Appendix F.2, Section 10.2, CAN/CSA-C61000-3-6, IEEE 1547

Power Factor

Power factor is a measure of apparent power delivered when the voltage and current waveforms are out of synch. Power factor is the ratio of true electric power, as measured

in kilowatts (kW), to the apparent power, as measured in kilovolt-amperes (kVA). The power factor can range from a worst case of zero when the current and voltage are completely out of synch to the optimal value of 100% when the current and voltage are entirely in synch. The terms "leading" and "lagging" refer to whether the current wave is ahead of or behind the voltage wave and are a contributor to the efficiency or inefficiency of the utility's electrical system. Distributed generators connected to the distribution system must operate in the range 0.9 lagging to 0.95 leading power factor.

Ref: OEB DSC, Appendix F.2, Section 4

DC injection

DC Injection is a potential issue for inverters where an inverter passes unwanted DC current into the AC or output side. This can be prevented by the incorporation of equipment and design to prevent or limit the effect.

Ref: OEB DSC, F.2, Section 10.3

Voltage Flicker

Somewhat like voltage fluctuations, voltage flicker refers to short-lived spikes or dips in the line voltage that are noticeable to the eye and annoying. It can occur when the outputs from a distributed generator vary for example with some wind turbines if the wind is gusting or turbulent.

Ref: OEB DSC, Appendix F.2, Section 10.1

Protection of A distributed energy resource Facility

The distributed energy resource developer will be responsible for protecting its distributed energy resource facility equipment in such a manner that distribution system faults - such as outages, short circuits, automatic reclosing of distribution circuits, or other disturbances - do not damage the distributed energy resource facility equipment. The equipment protection shall also prevent the distributed energy resource facility from adversely affecting the distribution system's capability of providing reliable service to other customers.

Ref: OEB DSC, Appendix F.2, Section 2

Isolating Device

The isolating device is a means of electrically disconnecting the generation facility from Halton Hills Hydro's distribution system. Such a device is required at all distributed energy resource facilities and shall:

- Be compliant with the Ontario Electrical Safety Code;
- Be able to operate the switch under rated load;
- Must have open and closed positions clearly indicated;
- Must be accessible to Hydro staff and be in a well-lit, non-hazardous location;
- Must be located upstream of all generation equipment including related switches, and step-up transformers;
- Must be as close as possible to the generation meter. Must be located on the generation side of the meter. Where the voltage is three phase, an isolating device must be installed on the utility and generation sides of the meter to allow the meter to be completely isolated;
- Must have provisions to be locked (i.e.: pad lockable)
- Must be gang operated so as to not single phase three-phase loads;
- Must not endanger the person(s) operating the switch;
- May be required to be motorized for generation exceeding 250kW. If the switch is motorized, the power source for its operation must be reliable and may require back-up battery power to operate the switch. Halton Hills Hydro will make this decision;
- Generator/ Halton Hills Hydro operation of the switch should be coordinated with the other party prior to operating the switch. Procedures for tagging and lockout should be reviewed by both parties;
- Where the isolating device is located inside a building or structure, the Generator shall provide HHH with keys to access it prior to connecting the generation.

Monitoring and Recording

For micro-generation (up to 12kW), unless otherwise required by Halton Hills Hydro, the Generator, or if required by a government program, remote monitoring and access using a telecommunications medium is not required. The Generator should monitor their system and report any abnormalities to Halton Hills Hydro or when requested by Halton Hills Hydro provide a record of abnormalities in the generating system.

For distributed energy resources greater than 250 kW, Halton Hills Hydro may require remote monitoring of the distributed energy resource site. Elements that may require remote monitoring access provided to Halton Hills Hydro are:

- Connection status;
- Isolating Device status (open/ closed);
- Real and Reactive Power output (kW and KVAR);
- Voltage (line-to-line & line-to-neutral) and neutral voltage at the point of generator connection;
- Current (amps) for each phase and neutral;
- Frequency;
- Alarms.

The generator shall keep a record of any events relating to the above items that are outside of the normal operating conditions/ parameters of the generation facility. Such record should be made available to Halton Hills Hydro within 5 days upon such a request.

The monitoring devices should be capable of recording event times in Coordinated Universal Time (UTC) or Eastern Standard Time formats.

Power quality (PQ) may be monitored at all facilities with a nameplate rating of 100kW up to 250kW. Where monitoring is employed, Halton Hills Hydro requires physical and telemetric access to the PQ device. The device must be able to communicate with Hydro using DNP 3.0 protocol via Ethernet or telephone ports. In some instances, wireless access may be permitted. The PQ device shall be capable of monitoring:

- Voltage sags and swells;
- Voltage and current channels simultaneously;
- Power interruptions;
- Undervoltage and Overvoltage;
- Frequency;
- Harmonics.

Ref DSC Appendix F.2, Section 3, 9, and 10.

Power quality (PQ) may be monitored at all facilities with a nameplate rating greater than 250kW. Where monitoring is employed, Halton Hills Hydro requires physical and telemetric access to the PQ device. The device must be able to communicate with Hydro using DNP 3.0 protocol via Ethernet or telephone ports. In some instances, wireless access may be permitted. The PQ device shall be capable of monitoring:

- Voltage sags, swells, transients;
- Current transients;
- Voltage and current channels simultaneously;
- Power interruptions;
- Undervoltage and Overvoltage;
- Frequency;
- Harmonics (fundamental to the 64th);
- A period of waveform before and after the event;
- Duration of the event along with a date and timestamp.

Ref DSC Appendix F.2, Section 3, 9, and 10.

Halton Hills Hydro Inc. will specify the PQ monitoring device to allow integration into existing PQ monitoring systems. The above requirements for monitoring and recording may apply and can vary depending on other details presented during the review of an application. It is possible that upstream or downstream LDC's may require additional monitoring for which Halton Hills Hydro and the Generator will need to comply.

Ref DSC Appendix F.2, Section 9

For distributed energy resources greater than 10 MW the monitoring must be in real time having the same minimum requirements as previously stated.

Ref DSC Appendix F.2, Section 9

Remote Access, Control, and Telecommunications

Remote site access shall be provisioned for all non-micro-generation facilities connected to Halton Hills Hydro's distribution system.

The Generator shall provide real time monitoring and data pertaining to their facility and its equipment. Real time data shall be provided directly from the Generators facility equipment (Intelligent Electronic Device) or SCADA master. Transmission of real time data should utilize DNP 3.0 protocol for communication to Halton Hills Hydro's office.

Battery Backup of the monitoring, control, and telecommunications equipment should be installed to support the access to information in the event of a system outage.

Provisions for remote access and control of the main disconnecting/ isolating device and/or load break switch (i.e.: interconnecting switch at the PCC) may be required. Halton Hills Hydro Inc shall specify if and when such provisions are required and if and when full remote control/ operation is required.

Halton Hills Hydro Inc. may request GPS coordinates of the Generation facility to evaluate the possibilities of wireless communication of its smart metering and SCADA systems.

Where real time monitoring and data is required and a sufficient wireless signal cannot be achieved:

- Direct connection using an Ethernet communication device will be required at the equipment to be monitored.
- A wireless signal boosting device or repeater may be required.
- Other options suitable for the site shall be evaluated.

Typically, the Generator will supply and install all remote monitoring, control, and telecommunication equipment (hardware, firmware, and software) up to the demarcation point and provide Hydro with remote access to such equipment. The Generator shall submit equipment details to Halton Hills Hydro Inc. for review and approval. If required, Halton Hills Hydro Inc shall determine, provide, own, and operate the appropriate telecommunications and PQ equipment. Such equipment will be supplied at the Generators expense.

- Note: Halton Hills Hydro will provide the revenue meter, which may have power quality monitoring capabilities, at the customer's expense. See "Metering" for more information.

Requirements by Generation Size

Generation facilities with a name plate rating of less than 100kW shall have provisions for monitoring the disconnecting/ isolating device within the generation facility and load break switch at the PCC. Micro-generation (12kW or less) not included unless otherwise specified by HHH.

Provisions for other data such as voltage, current, frequency, and power quality may be required and will be determined by Halton Hills Hydro.

Generation facilities with a name plate rating of 100kW up to 250kW may be required to provide Halton Hills Hydro with the following real time data:

- Delivered and Net active power (kW) output and reactive power (kVAR);
- Phase-to-phase and phase-to-neutral voltages;
- All phase currents;
- Neutral voltage and current;
- Harmonics;
- Power quality items previously mentioned.

Generation facilities with a name plate rating of 251kW up to 500kW may be required to provide the following. 501kW up to 10MW shall provide Halton Hills Hydro with the following real time data:

- Delivered and Net active power (kW) output and reactive power (kVAR);
- Phase-to-phase and phase-to-neutral voltages;
- All phase currents;
- Neutral voltage and current;
- Harmonics (to the 64th).
- Power quality items previously mentioned.
- Where required, device statuses including isolating device, load break switch, low voltage breakers, interrupters, and circuit switchers at the PCC. Status of automatic voltage regulators and power system stabilizers that impact the distribution system. Generation facility offline tripping and reason.

Ref DSC Appendix F.2, Section 9

Alarm provisions shall be installed and enabled (where required) to be transmitted to Halton Hills Hydro for the following:

- Generator owned isolating device opened;
- Hydro owned interconnecting distribution switch opened;
- Loss of communications;
- Loss of Generator owned protections (failed or disabled);
- Loss of Hydro owned protections (failed or disabled);
- Transfer/ Trip signal;
- The alarms shall identify the Generation facilities name, affected equipment, and affected circuit.

When an alarm is generated or equipment status is changed, the signal should be able to reach Halton Hills Hydro's SCADA master within 10 seconds from the change in the field. Typical updating of devices statuses and monitored data should be no more than 60 seconds. The Generator should install equipment that allows HHH to poll any specific point being monitored on demand.

Where an alarm is generated due to customer owned equipment, the Generator shall inform HHH of the reason for the alarm and the estimated time to repair the equipment. The Generator should coordinate all planned interruptions of delivering real time data with Halton Hills Hydro Inc.

Depending on the requirements of upstream or downstream LDC's or transmitters, other needs for monitoring and telecommunications may be required. In these instances, Halton Hills Hydro will work with the LDC(s) or transmitter(s) and the Generator to achieve the requirements of all parties.

Standardized or Certified Equipment

It is a requirement that the design for a distributed energy resource installation be approved by a professional engineer and that all equipment be CSA approved and inspected by the ESA. However, if the interface equipment used is a standard package or certified for use (by UL or CSA or some other recognized approving body), as is the case with some inverters, this will expedite and simplify the interconnection process. This is especially applicable at the lower distributed energy resource output levels and will reduce the amount of technical information required.

The safety, power quality and reliability of interconnected distributed energy resources is ensured through design, standards, inspection, testing and the provision of switches, breakers and protective relaying incorporated into the distributed energy resource or as auxiliary equipment. A brief summary is as follows:

- An interrupting device capable of interrupting the maximum available fault current at the distributed energy resource location.
Ref DSC Appendix F.2, Section 1
- An interconnection device that is manual or motorized, lockable, has visible disconnection and is accessible to HHH staff. Ref DSC Appendix F.2, Section 1
- A generator disconnect device. Ref DSC Appendix F.2, Section 1
- Anti-islanding protection. Ref DSC Appendix F.2, Section 6.1.2
- A protective relay that will operate the load interruption device with the following features
 - Over-voltage trip. Ref DSC Appendix F.2, Section 1 and 6.5
 - Under-voltage trip. Ref DSC Appendix F.2, Section 1 and 6.5
 - Over/under frequency trip. Ref DSC Appendix F.2, Section 6.5
 - Over current protection. Ref DSC Appendix F.2, Section 6.4
 - Ground fault protection. Ref DSC Appendix F.2, Section 2
- Reclosing co-ordination to ensure that the distributed energy resource ceases to energize prior to the reclosure of an upstream HHH device. Halton Hills Hydro will inform the Generator of re-closing requirements and timing as this can vary depending on the feeder being connected into. Ref DSC Appendix F.2, Section 6
- Power Factor correction (if required). Ref DSC Appendix F.2, Section 4
- Synchronizing equipment that will limit voltage fluctuation, frequency variation and phase angle when the distributed energy resource parallels with the distribution system. Ref DSC Appendix F.2, Section 3.2
- Transfer Trip may be required depending on the loading of the distribution feeder and the output rating of the distributed energy resource relative to the feeder loading.
- Feeder Relay Directioning to prevent inadvertent tripping of a protective device for faults not associated with the protection zone of the device. Ref DSC Appendix F.2, Section 8



Halton Hills Hydro will provide approximate three phase fault levels at the preliminary review stage. A protection co-ordination study will be required which may involve alternate supplies from different sources. Protection design and ratings should account for these variables.

Preliminary Review, Technical Review, Impact Assessment

Generation Connection Process

As stated previously, the process that Halton Hills Hydro will follow for connecting a distributed generator to HHH's distribution system is detailed in the OEB's Distribution System Code, Appendix F. The starting point is for potential Generators to complete the DER Preliminary Consultation Information Request (PCIR) Form (Appendix 2) and return it to Halton Hills Hydro's Engineering Department.

Preliminary Review

The Preliminary Consultation Report (PRC) is provided to the generator within 15 days. In the very early stages where a Generator may be considering site selection, Halton Hills Hydro will provide a preliminary review and high-level advice and guidance based on limited parameters such as:

- Potential sites
- Output capacity of the distributed energy resource
- Fuel type
- Generator generic description and design type

To better assist you in determining the feasibility of your proposed generation facility and if you can make money generating electricity from renewable energy projects, visit the Canadian Government's [RETScreen International Clean Energy Decision Support Centre](http://www.retscreen.net/ang/d_o_view.php) at http://www.retscreen.net/ang/d_o_view.php. This free, online tool will provide a financial analysis of your small scale energy *project*. Halton Hills Hydro only offers this as a reference and shall not be held liable for the information it contains, information gathered from it, or decision making based on information gathered from this Government of Canada's service.

Technical Review

Once a location has been determined, the Generator must complete an application form Appendix 3: Generator Connection Assessment Review Form (12 kW or Less) or Appendix 4: Connection Impact Assessment (CIA) Application (12 kW to 10MW) requesting a full technical review. The technical review will establish HHH's requirements for the distributed energy resource at the specific location and determine the need for an Impact Assessment.

The technical review will require the distributed energy resource developer to provide the following details of the project certified by a licensed professional engineer:

Distributed Energy Resource Description

- Site
- Type of distributed energy resource
- Output including seasonal and daily variations
- Number of units initially and ultimately, if future expansion is applicable
- Time line for construction and commissioning
-

Single Line Electrical Diagrams (with ratings or sizes detailing)

- Point of connection to the distribution system
- Generator
- Generator disconnect device
- Protective relaying and functions
- Transformer
- Protective isolating device
- Generator breaker
- Manual interconnection disconnection device
- Voltage levels
- Fusing

Nameplate data or manufacturers specs on:

- Protective relays
- Synchronizing device
- Fault calculations, protective relay settings, fuse specification
- Short circuit and voltage drop studies
- Station service and battery system
- Grounding studies
- Load interrupter switch or circuit breaker
- Dedicated interconnection transformer
- Isolating device for interconnection
- Protection system and operating procedures including schematics

LDC Impact Assessment

Where required, Halton Hills Hydro will perform an impact assessment and advise the Generator of compliance and permission to proceed or of problems that need to be addressed. Prior to the impact assessment, the Generator will be required to enter into a "Study Agreement" with Halton Hills Hydro (Appendix 9). The Generator should not order any equipment or make commitments to the project until the impact assessment has been satisfactorily completed and a Distribution Connection Agreement has been executed. When a Generators licence is required, Halton Hills Hydro will require a copy of the Generators Generator Licence.

The impact assessment shall set out the impact of the proposed generation facility on the distribution system and any customers of the distributor including:

- a. any voltage impacts, impacts on current loading settings and impacts on fault currents;
- b. the connection feasibility;
- c. the need for any line or equipment upgrades;
- d. the need for transmission system protection modifications; and e. any metering requirements.

The technical submission for projects greater than 12kW (single line diagram, Generation Connection Assessment Form, site plan, etc...) must be signed and sealed by a Professional Engineer licensed by the Professional Engineers of Ontario.

Hydro One Impact Assessment

Distributed energy resources greater than 500 kW connected to HHH's 27.6 kV and 44 kV systems may have an impact on Hydro One's electrical supply system and will require their separate impact assessment.

Hydro One may request or be required to perform their own impact assessment on any size project connecting to HHH's distribution system. Any costs incurred by HHH applying to Hydro One on behalf of a Generator will be borne by the Generator.

Costs

The Generator will be required to pay Halton Hills Hydro for processing and reviewing any application, technical review and impact assessment. The cost may vary from a fixed fee approved by the OEB to actual costs for time required. Contact Halton Hills Hydro for details.

In addition, Halton Hills Hydro will add any costs incurred for reviews or assessments required by Hydro One or other LDC's where applicable.

Halton Hills Hydro will charge actual costs for labour and materials for any distribution system upgrades or line extensions required including but not limited to increased transformer capacity requirement, primary or secondary conductor, line extensions, switches and associated distribution hardware.

Where the distributed energy resource is non-exporting to offset existing load, a standby charge may be applicable as approved by the OEB.

The Generator is solely responsible for the purchasing, installing, inspections, testing/ commissioning and other related items for their generation facility. Halton Hills Hydro shall not be held liable for the costs incurred by the Generator during the course of the project.

Production and Commissioning Tests

Prior to a generation facility of size 12kW or larger being allowed to connect to the distribution system, the Generator in coordination with Halton Hills Hydro must complete a "Commissioning and Equipment Verification Report" found in Appendix 7 of these Guidelines. Areas of this Report not shaded must be completed by the Generator and/ or their representatives. The Report must be signed and sealed by a Professional Engineer who is acting on the Generator's behalf and who is registered with Professional Engineers Ontario.

The Applicant should submit their Commissioning Plan to HHH at least 5 business days prior to the commissioning test date.

Commissioning and Verification tests shall be performed per CSA C22.3 No. 9-08 "Interconnection of Distributed Resources and Electricity Supply Systems", IEEE 1547 "Standard for Interconnecting of Distributed Resources with Electric Supply Systems" and The OEB Distribution System Code Appendix F.2 "Technical Requirements".

The Generator will be required to pay the costs related to production and commissioning tests if these tests are required.

Commissioning Test and ESA Connection Authorization, Ref DSC 6.2.19, 6.2.20, and Appendix F.

Termination of Process (Prior to Connection)

If at any time during the course of the project, prior to enacting the Connection Agreement and connecting the generation the Generator decides for whatever reason that they do not wish to proceed any further, the Generator shall notify Halton Hills Hydro in writing of their intent to terminate the process. Once notification is received, Halton Hills Hydro personnel will contact the Generator to confirm the termination notification and proceed with terminating the processes of Halton Hills Hydro's involvement. However, due to equipment and labour hour costs, Halton Hills Hydro reserves the right to determine what funds will be reimbursed to the Generator assuming payment for the work was made to the utility by the Generator prior to terminating the process.

Metering

Metering requirements will be determined by Halton Hills Hydro in accordance with Section 2.3.8 “Metering” and “Table A” of the Conditions of Service. Metering will also depend on the type and size of generation and the load, if any, where the distributed generator is also a customer, at the distributed energy resource location. Where the distributed generator is exporting power a bi-directional meter capable of measuring electricity received from and sent to the distribution system is required. If power quality monitoring is required (see “Monitoring and Recording”), Halton Hills Hydro may require a sophisticated meter capable of monitoring, recording, and transmitting power quality data and events to the office. Halton Hills Hydro will purchase and supply an appropriate sealed meter at the Generator’s expense once a connection cost recovery agreement has been completed by Halton Hills Hydro, signed by the Generator, and returned to the Hydro office with payment.

All metering cabinets, instrument transformers, and if necessary a telecommunications line will be supplied and installed by the Generator and owned by Halton Hills Hydro. All meters must be accessible to Halton Hills Hydro. Where meters are located inside a building or structure, the Generator shall provide keys to Halton Hills Hydro to access the meter and isolation device prior to connection. All internal meter and isolating device locations must be in a well-lit, obstruction free area, preferably not accessible to the public.

The metering may be installed at the Demarcation Point of connection of the Distributed energy resource Facility to the Distribution System. The point of demarcation for a Distributed energy resource Facility is the primary live line clamp or lines switch that is installed on or at Halton Hills Hydro’s Distribution line. If this is not practical, Halton Hills Hydro shall apply loss factors to the generation output in accordance with the loss factors applied for Retail settlements and billing. Appendix 6 shows the metering location and configuration options.

Any Generator has the right to be a participant in the IESO-controlled wholesale market for settlements. Participants in the wholesale market must meet the requirements as specified in Chapter 6 Wholesale Metering of the Market Rules. In general, the metering requirements for wholesale market participants are more stringent than those required for HHH retail revenue purposes. In both wholesale and retail markets, all meters and instrument transformers must be Measurement Canada approved and connected in accordance with Measurement Canada and OEB policies and procedures. However, in the wholesale market, the IESO requires that market participants engage the services of a Meter Service Provider (MSP) to install and maintain the metering system. In addition, the IESO specifies the number and types of meters that must be used for revenue purposes and requires the submission of an emergency instrument transformer restoration plan.

Unless otherwise specified for micro-generation projects, meter wiring shall follow ESA Specification 004 “Guidelines for Inverter-Based Micro Generating Facilities” where the line side of the meter is connected to HHH’s distribution system and the load side of the meter is connected to the generation output.

Approvals

Before any distributed energy resource can be connected to Halton Hills Hydro's distribution system it must have received as a minimum the following approvals plus any additional approvals identified by Halton Hills Hydro and Hydro One:

- LDC Distribution Connection Agreement
- CSA or UL or recognized certification of all equipment installed
- ESA approval

Protection Philosophy Requirements

This section provides a summary of protection philosophy for non-exporting, inverter-based (NE/I) connections including storage, solar, and wind. It is intended as a guide for proponents regarding the kinds of protections, and particularly the categories of protections, that distributors will require for connection.

The protection system of the connection will be designed to:

- Detect internal faults with the generator facility, downstream of the Point of Common Coupling (PCC), and automatically disconnect the NE/I source
- Detect external faults on the utility feeder and automatically disconnect the NE/I source
- Detect islanding conditions and disconnect the NE/I source
- Detect export of power from the NE/I source to the utility feeder and automatically disconnect the NE/I source

Internal Faults within the Generator Facility

The following protections are in place to protect against internal faults resulting from the NE/I source:

- Multi-Function Relay-At the PCC, a multi-function relay will be installed to monitor internal faults resulting from the NE/I source. The 52 Trip Breaker will trip if it detects the following:
 - 25 - Synchronization Check
 - 27 - Undervoltage
 - 59 - Overvoltage
 - 81O/U - Under and Over Frequency
 - ID -Active Anti-Islanding
 - Inverter Breakers - Each inverter is equipped with an AC breaker at the output of the inverter providing additional overcurrent protection

Facility Overcurrent Protection - All circuits within the facility are protected from both phase-to-phase and phase-to-ground faults by appropriate overcurrent protection devices. Fuses are sized to clear under fault conditions within the generator facility

External Phase and Ground Faults in the Distribution System

The following protections are in place to protect against external faults resulting from the utility feeder:

Multi-Function Relay - At the main utility service, prior to the first facility load, a multi-function relay will be installed to monitor faults from the utility feeder. The 52 Trip Breaker at the NE/I source PCC will trip under the following faults:

- 27 - Undervoltage

- 32R- Reverse Power
- 50/51- Overcurrent
- 59 - Overvoltage
- 810/U - Under and Over Frequency
- 67 - Directional

Inverter Protection: The inverters proposed for this project are certified to UL 1741, IEEE 1547, and CSA C22.2 107.1-01 standards and will behave accordingly.

Anti-Islanding

The Energy Resource Facility will operate in a grid following mode and will not operate islanded.

Anti-Islanding Inverters - The NE/I source inverters contain both passive and active anti-islanding protection as required by IEEE 1547 and UL1741 SA. If the utility normal power supply is interrupted, the inverters detect the loss of power and disconnect.

Reverse Power

Reverse Power Protection - In addition to the multi-function relay at the utility supply monitoring reverse power (32R), the load is continually monitored to ensure the NE/I source discharge is below the consumption of the facility. This additionally protects against power injection to the utility grid.

Directional Overcurrent

Directional overcurrent protection - Directional overcurrent relays are normally used on incoming line circuit breakers on buses which have two or more sources. They are connected to trip an incoming line breaker for fault current flow back into the source, so that a fault on one source is not fed by the other sources.

Special Comment Regarding Inverter Based Generation

The inverters specified for this project have a limited fault current contribution.

Because inverters are current-limited devices, unlike rotating generators, the fault current is very close to the maximum output current, limiting the fault current in the system to 120% -140% of FLA.

Appendices

Appendix 1: (a) Definitions

Appendix 1: (b) Who's Who in Electricity

Appendix 2: DER Preliminary Consultation Information Request (PCIR) Form

Appendix 3: Generator Connection Assessment Review Form (12 kW or Less)

Appendix 4: Connection Impact Assessment (CIA) Application (12 kW to 10MW)

Appendix 5: ESA Guidelines for Inverter-Based Micro Generating Facilities

Appendix 6: Metering Configurations

Appendix 7: Commissioning and Equipment Verification Report

Appendix 8: Connection Agreements

Appendix 9: Study Agreement

Appendix 10: Regulatory and Industry Contacts

Appendix 1 (a): Definitions

**Appendix 1 (b): Who's Who in
Ontario Electricity**

APPENDIX 1 (a)

Definitions

Applicant — The legally responsible person applying to an LDC to interconnect a distributed generation facility to the LDC’s distribution system.

Application Review — A review by the LDC of the completed standard interconnection application form for interconnection, to determine if an engineering review or distribution system study is needed.

Back-up Power — Electric energy or capacity supplied by an LDC to replace energy ordinarily generated by distributed generation facility equipment during an unscheduled outage of the distribution system.

Certified Equipment — A generating, control or protective system that has been certified by a nationally recognized testing laboratory (NRTL) as meeting acceptable safety and reliability standards.

Commissioning Test — The initial process of documenting and verifying the performance of a distributed generation facility so that it operates in conformity with the design specifications.

Customer — Any person who is receiving electric service from an LDC’s distribution system.

Designated Point of Contact — Each LDC shall designate one point of contact for all customer inquiries related to distributed generation facilities and from which interested parties can obtain a copy of interconnection guidelines - which include the appropriate application forms and interconnection agreements.

Distributed Generation (DG) Facility — A facility for the generation of electricity with a capacity of no more than 15 megawatts that is located near the point where the electricity will be used or is in a location that will support the functioning of the electric power distribution grid.

Distributed Generation Developer — same as Applicant.

Distribution Feeder/Line — An electric line from an LDC substation or other supply point to customers that is operated at 50 kV or less, or as determined by the LDC.

Distribution Substation — A facility that reduces the voltage of the electricity supply from sub transmission voltages less than 50 kV to even lower distribution voltages less than 50 kV.

Distribution System — All electrical wires, equipment, and other facilities owned or provided by an LDC that are normally operated at 50 kV or less.

Distribution System Code — A code issued by the Ontario Energy Board that prescribes the requirements for local distribution companies and customers who are

served by the distribution system. Specifically, Appendices F of the code outlines the procedures to be followed for processing and connecting distributed generation facilities and F.2 is an overview of the technical requirements.
http://www.oeb.gov.on.ca/documents/dscappf_100304.pdf

Distribution System Study — A study to determine if a distribution system upgrade is needed to accommodate the proposed distributed generation facility and to determine the cost of any such upgrade.

Engineering Review — A study that may be undertaken by an LDC, in response to its receipt of a completed standard application form for interconnection, to determine the suitability of the installation.

ESA – Electrical Safety Authority

Fault — An equipment failure, conductor failure, short circuit, or other condition resulting from abnormally high amounts of current from the power source.

HOEP — The Hourly Ontario Energy Price is an average of the market price set at each five-minute interval within that hour.

IEEE — Institute of Electrical and Electronics Engineers.

Impact Assessments — if warranted by the size, type location or other factors impact assessments may be required by an LDC and in some cases Hydro One where the distribution lines connect to Hydro One transformer stations.

Independent Electricity System Operator (IESO) — An entity supervising the collective transmission facilities of a power region; the IESO is charged with nondiscriminatory coordination of market transactions, system-wide transmission operation, and network reliability.

Interconnection — The physical connection of a distributed generation facility to the distribution system so that parallel operation can occur.

Interconnection Agreement — a written set of operating procedures to specify how the distributed generator facility will interact with an LDC's distribution system and the responsibilities and accountabilities of the parties

Interconnection Disconnect Switch — A mechanical device used to disconnect a distributed generation facility from a distribution system. Also known as an isolation device.

Inverter — A machine, device or system that converts direct current power to alternating current power.

Islanding — A condition on the distribution system in which a distributed generation facility delivers power to customers using a portion of the distribution system that is electrically isolated from the remainder of the distribution system.

kV – kilovolt (1000 volts)

kW – kilowatt (1000 watts)

Local Distribution Company — A local distribution company or LDC manages and operates the electricity distribution system and currently bills for electricity services at the retail level in Ontario.

MW – megawatt (1000 kW)

Material Modification – Any modification that changes the maximum electrical output of a distributed generation facility or changes the interconnection equipment, including:

- a) Changing from certified to non-certified devices.
- b) Replacing a component with a component of different functionality or Underwriters Laboratories listing.
- c) Changes to the Interconnection Point

Nationally Recognized Testing Laboratory — Any testing laboratory recognized by the ESA, or CSA as having an approved equipment accreditation program.

Net metering — An arrangement where distributed generation facilities can offset their associated load consumption and are compensated for any extra energy delivered to the electricity system. In Ontario, legislation permits distributed generation facilities using renewable resources with a capacity of 500 kW or less to be eligible for net metering.

OEB — Ontario Energy Board

Parallel Operation — The operation, for a finite time, of a distributed generation facility while the facility is connected to the energized distribution system.

Paralleling Equipment — The generating and protective equipment system that interfaces and synchronizes a distributed generation facility with the distribution system.

Point of Common Coupling — The point where the electrical conductors of the distribution system are connected to the customer's conductors and where any transfer of electric power between the customer and the distribution system takes place.

Point of Interconnection — The point where the distributed generation facility is electrically connected to the customer's electrical system.

Preliminary Review — A review at the feasibility stage to determine the suitability of a distributed generation site and the LDC's facilities available for connection

Protective Function — A function of a distributed generation facility, carried out using hardware and software, designed to prevent unsafe operating conditions from occurring before, during, and after the interconnection to a distribution system.

Supervisory Control and Data Acquisition (SCADA) — A system of remote control and telemetry used to monitor and control the electric system.

Switchgear — Components for switching, protecting, monitoring and controlling electric power systems.

Synchronize — The process of connecting two previously separated alternating current apparatuses after matching frequency, voltage, phase angles, etc. (e.g., paralleling a generator to the electric system).

Technical Review — a more comprehensive evaluation of the distributed generation proposal than the preliminary review to establish that the proposal and the equipment meet the technical guidelines for safety, power quality and reliability.

Telemetry — The transmission of distributed generation operating data using telecommunications techniques.

Transfer Switch — A switch designed so that it will disconnect the load from one power source and reconnect it to another source.

Transformer Station — A facility that reduces the voltage of the electricity supply from transmission voltages greater than 50 kV to distribution voltages less than 50 kV.

UL — Underwriters Laboratories.

Unit — same as distributed generation facility.

APPENDIX 1 (b)

Who's Who in Ontario Electricity

Sometimes it's difficult to figure out who's who and what they do in Ontario's electricity system. Here's a brief overview:

The Ontario Government and the Ontario Ministry of Energy	<ul style="list-style-type: none">• Establish public policy, pass legislation and regulations relating to electricity• Create other agencies IESO, OPA, OEB, etc., and establish raison d'être for Hydro One, OPG and LDCs• Significant legislation: Electricity Act, 1998 and Regulations, Ontario Energy Board Act 1998, Electricity Restructuring Act 2004• Shareholder of Hydro One and OPG
Independent Electricity System Operator (IESO)	<ul style="list-style-type: none">• The Independent Electricity System Operator (IESO) operates and manages Ontario's electricity system at the generation and transmission level. It does not design, build or own the system; it coordinates how the system interacts and performs and it monitors the performance, reliability and future adequacy of the system to provide electricity to Ontarians. The IESO creates electricity market rules, matches generation with load 24/7, establishes the Hourly Ontario Energy Price (HOEP) and settles wholesale electricity payments.
Ontario Ministry of Environment (MOE)	<ul style="list-style-type: none">• The Ontario Ministry of Environment (MOE) sets environmental standards for electricity projects in Ontario and ensures that generators, distributors and transmitters follow rules and standards when constructing and operating facilities.

<p>Ontario Energy Board (OEB)</p>	<ul style="list-style-type: none"> • The Ontario Energy Board (OEB) is the province’s electricity regulator and is responsible for protecting the interests of consumers with respect to prices, reliability, adequacy and quality of electricity service and to promote economic efficiency of generation, transmission and distribution. The OEB approves the rates charged by transmitters (greater than 50 kV) and distributors (less than 50 kV) and creates codes and regulations for certain aspects of how transmitters and distributors conduct their business. • The OEB issues licenses for generators, transmitters, distributors, and retailers. • The OEB does not set rates for generation; that is a competitive process either through the Hourly Ontario Energy Price or third party contracts, but it has set prices for small consumers.
<p>Ontario Power Generation (OPG)</p>	<ul style="list-style-type: none"> • Ontario Power Generation (OPG) owns and operates most of Ontario’s generating capacity. It is owned by the Province of Ontario.
<p>Hydro One Networks (HONI)</p>	<ul style="list-style-type: none"> • Hydro One is the province’s largest transmission company and owns the provincial transmission grid. Hydro One also distributes electricity outside of the major urban centres. It supplies LDCs from TSs at 27.6 kV and 44 kV or DSs at lower voltages. Some distributed generation connected to Hydro One TSs or DSs will require co-ordination with Hydro One. Hydro One is owned by the Province of Ontario.
<p>Electrical Safety Authority (ESA)</p>	<ul style="list-style-type: none"> • The Electrical Safety Authority (ESA) is responsible for ensuring that electrical equipment is installed safely and meets required standards in accordance with the Ontario Electrical Safety Code.
<p>Measurement Canada (MC)</p>	<ul style="list-style-type: none"> • Measurement Canada (MC) is a federal agency of Industry Canada with the mandate of regulating meters and metering throughout the country. MC administers the Electricity and Gas Inspection Act. R.S. 1985, C.E-4.

Appendix 2

DER Preliminary Consultation Application Form

Preliminary Consultation Information Request (PCIR)

1. Instruction

The Applicant should only proceed with this form if the proposed DER project meets the following conditions:

- a) Has a capacity larger than 12kW (AC).
- b) Not a sole emergency backup generator during a power interruption to the distribution system.

For a micro DER project with a capacity size of 12kW or less, please review the Local Distribution Company (Distributor)'s website for application process.

The Applicant should complete the latest version of the PCIR form, and submit the form per the instruction provided on the Distributor's website. All fields are required, unless otherwise noted, to enable the preliminary connection assessment. The Applicant does not need to commit to any information provided in the PCIR. Changes can be made when applying for a Connection Impact Assessment (CIA). Please note that the preliminary consultation process does not consider the full range of technical evaluations that would be performed through a CIA. The PCR provides additional information on the potential complexity of the connection of the proposed DER. Capacity is not reserved upon completion of a Preliminary Consultation Report (PCR).

Please check the Independent Electricity System Operator (IESO)'s website for information on the System Impact Assessment if the Applicant plans to provide ancillary services.

All kW capacity information in this form should be in AC.

2. Distributor Contact Information**2.01 Contact Information**

A. Distributor Name	-	Halton Hills Hydro Inc.	Pre-populated by Distributor
B. Department Name	-	Engineering	Pre-populated by Distributor
C. Department Address	-	43 Alice Street	Pre-populated by Distributor
D. Department City & Postal Code	-	Acton, On	Pre-populated by Distributor
E. Department Fax	-	-	Pre-populated by Distributor (Optional)
F. Department Phone	-	519-853-3700 Ext. 213	Pre-populated by Distributor
G. Department Email	-	HHHEngineering@haltonhillshydro.com	Pre-populated by Distributor

3. General**3.01 Application Information**

A. Project Name	-	-
B. Application Submission Date	Date	Format: YYYY-MM-DD

3.02 Applicant Information

A. Applicant (Company Name)	-	-
B. Applicant Type	Select	-
C. Applicant Representative (Individual Name)	-	-
D. Applicant Address	-	Corporate Address (if applicable)
E. Applicant City	-	-
F. Applicant Postal Code	-	Format: A0A 0A0
G. Applicant Fax	-	Optional
H. Applicant Phone	-	Format: XXX-YYY-ZZZZ
I. Applicant Email	-	-

Preliminary Consultation Information Request (PCIR)

4. Project Information

4.01 Project Nameplate & Type

A. Proposed Capacity (Aggregate)	kW		AC capacity
B. Exporting/Non-Exporting	Select		Indicate if capable of exporting to grid
C. Proposed Export Capacity (Aggregate)	kW		If capacity is different from Proposed Capacity
D. Connection Type (Single/Three-Phase)	Select		-
E. Inverter-Based/Non-Inverter-Based	Select		-

4.02 Proposed DER Fuel/Energy Type

Please use the selection below to identify the proposed DER fuel/energy type.			
A. Solar	kW		-
B. Wind	kW		-
C. Water (Hydroelectric)	kW		-
D. Biofuel/Biogas	kW		-
E. Thermal	kW		Other than biofuel
F. Energy Storage (including bi-directional EV)	kW		-
G. Other	Specify		Enter specific technology type and kW information

5. Site Information

5.01 Existing Account Holder

A. Existing Account Number (if Applicable)	-		Required if applicable
B. Existing Account Holder Name (if Applicable)	-		Required if applicable

5.02 Site Information

A. Site Address	-		Location of proposed facility
B. Site City/Town/Township	-		-
C. Site Postal Code	-		-
D. Site GPS Co-ordinates	-		Required for rural locations

5.03 Existing DERs at Site

If the Applicant has existing DER(s) at the same project site, please provide information required below to ensure proper preliminary connection assessment. If there is a variety of fuel/energy types, please explain in section "6.01 Other Information" below.			
A. Existing DER Capacity (Aggregate)	kW		Required if existing DER(s) installed
B. Existing DER Connection (Single/Three-Phase)	Select		Required if existing DER(s) installed
C. Existing DER Type (Inverter/Non-Inverter)	Select		Required if existing DER(s) installed
D. Existing DER Intent (Exporting/Non-Exporting)	Select		Required if existing DER(s) installed

Preliminary Consultation Information Request (PCIR)

6. Other Information

6.01 Other Information

A. In the comment box below, the Applicant can provide any additional information that is required as indicated in the above section(s) or considered beneficial for the purpose of obtaining a preliminary connection assessment.

B. If the Applicant chooses to provide accompanying documents, please list them below.

7. Distributor Office Use Only (Optional)

7.01 PCIR Status

A. Date Received	Date	Completed by Distributor
B. Date Returned Incomplete	Date	Completed by Distributor
C. Date Preliminary Consultation Report Issued	Date	Completed by Distributor

Distributed Energy Resource (DER) Connection

Preliminary Consultation Report (PCR)

1. Information

The Applicant should only proceed with this form if the proposed DER project meets the following conditions.

- a) Has a capacity larger than 12kW (AC).
- b) Not a sole emergency backup generator during a power interruption to the distribution system.

For a micro DER project with a capacity size of 12kW or less, please review the Local Distribution Company (Distributor)'s website for application process.

The Applicant should complete the latest version of the PCIR form, and submit the form per the instruction provided on the Distributor's website. All fields are required, unless otherwise noted, to enable the preliminary connection assessment. The Applicant does not need to commit to any information provided in the PCIR. Changes can

2. Distributor Contact Information

2.01 Contact Information

A. Distributor Name	-	Halton Hills Hydro Inc.	Completed by Distributor
B. Department Name	-	Engineering	Completed by Distributor
C. Department Address	-	43 Alice Street	Completed by Distributor
D. Department City & Postal Code	-	Acton, On	Completed by Distributor
E. Department Fax	-	-	Completed by Distributor (Optional)
F. Department Phone	-	519-853-3700 Ext. 213	Completed by Distributor
G. Department Email	-	HHHEngineering@haltonhillshydro.com	Completed by Distributor

3. General Application Information

3.01 Administration

A. Project ID	-		Assigned by Distributor
B. Project Name	-	--	As provided by customer
C. Report Date	Date		Assigned by Distributor

3.02 Applicant Information

A. Applicant (Company Name)	-	--	As provided by customer
B. Applicant Representative Email	-	--	As provided by customer

3.03 Project Nameplate & Type

A. Proposed Capacity (Aggregate)	kW	--	As provided by customer
B. Exporting/Non-Exporting		--	As provided by customer
C. Proposed Export Capacity (Aggregate)	kW	--	As provided by customer
D. Connection Type (Single/Three-Phase)		--	As provided by customer
E. Inverter-Based/Non-Inverter-Based		--	As provided by customer

3.04 Proposed DER Fuel/Energy Type

A. Solar	-	--	As provided by customer
B. Wind	-	--	As provided by customer
C. Water (Hydroelectric)	-	--	As provided by customer
D. Biofuel/Biogas	-	--	As provided by customer
E. Thermal	-	--	As provided by customer
F. Energy Storage (including bi-directional EV)	-	--	As provided by customer
G. Other	Specify	--	As provided by customer

3.05 Site Information

A. Site Address	-	--	As provided by customer
B. Site City/Town/Township	-	--	As provided by customer
C. Site Postal Code	-	--	As provided by customer
D. Site GPS Co-ordinates	-	--	As provided by customer

Distributed Energy Resource (DER) Connection**Preliminary Consultation Report (PCR)****3.06 Existing DERs at Site**

A. Existing DER Capacity (Aggregate)	kW	--	As provided by customer
B. Existing DER Connection (Single/Three-Phase)	-	--	As provided by customer
C. Existing DER Type (Inverter/Non-Inverter)	-	--	As provided by customer
D. Existing DER Intent (Exporting/Non-Exporting)	-	--	As provided by customer

4. Connection Overview**4.01 Site Connection Information**

A. Existing Site Distribution Transformer Capacity	kVA		If customer owned, Applicant is to confirm with CIA application
B. Existing Site Distribution Transformer Ownership	Select		Distributor or Customer-Owned
C. Existing Connection Voltage	kV		-
D. Distributor Asset ID (if Applicable)	-		Transformer ID, Vault ID, etc.

4.02 Distribution System Assets

A. Distributor Name	-	Halton Hills Hydro Inc.	Same as 2.01-A above
B. Distribution Station Name	-		-
C. Distribution Feeder Designation	-		-
D. Distribution Feeder Voltage	kV		-

4.03 Upstream Distribution Assets (if Applicable)

A. Upstream Distributor Name	-		-
B. Upstream Distribution Station Name	-		-
C. Upstream Distribution Feeder Designation	-		-
D. Upstream Distribution Feeder Voltage	kV		-

4.04 Transmitter

A. Transmitter Name	-		-
B. Transformer Station Name	-		-
C. Subtransmission Feeder Designation	-		-
D. Subtransmission Feeder Voltage	kV		-

4.05 Other Comments

A. Additional information not reported in the prescribed fields above (optional).

5. Preliminary Assessment of Connection Complexity

In order to provide an earlier indication of the anticipated complexity of a connection, this section provides an initial assessment of likely connection requirements and their complexity levels. These requirements are typically based on judgment or simplified criteria, and would be subject to change through the CIA process and further consultation with upstream utilities, including host Distributor and the transmitter. Further, this preliminary assessment does not evaluate the potential for the full range of requirements set through the CIA process. Please also review section 6.01 for additional insight on areas of uncertainty.

The following are four potential complexity tiers.

- Extremely High: Projects that are characterized as having “extremely high” complexity are likely not viable without entering a flexible hosting capacity arrangement, due to the nature of system constraints that preclude the connection of the contemplated DER facility.
- High: Projects that are characterized as having “high” complexity can be made viable through a combination of transmission, distribution or customer-side infrastructure upgrades.
- Medium: Projects that are characterized as having “medium” complexity can be made viable through a combination of distribution system upgrades. Transmission system upgrades are most likely not required. Customer-side infrastructure upgrades may be required.
- Low: Projects that are characterized as having “low” complexity are viable with minor distribution system modifications. Transmission system upgrades are most likely not required. Customer-side infrastructure upgrades may be required.

No.	Item	Impact	Preliminary Assessment	Comments
5.01	Station Constraints			
	If this section identifies a thermal constraint or a short circuit constraint, it is most likely the proposed project would not be able to connect.			
	A. Thermal	Ex. High		
	B. Short Circuit	Ex. High		
5.02	Anticipated Impact Assessments Required			
	This section provides details about the connection study(ies) required for the proposed DER project as guidance only and does not assume the outcome of the CIA.			
	Please consult the Distributor website for instructions on how to apply for a CIA.			
	Please check the Independent Electricity System Operator (IESO)'s website for information on the System Impact Assessment if the Applicant plans to provide ancillary services.			
	A. Distributor CIA	Select		<i>Move to section 5.06 if no Distributor CIA required due to a capacity constraint and the distributor doesn't offer flexible hosting capacity arrangement</i>
	B. Host Distributor CIA	Medium		-
	C. Transmitter CIA	Medium		-
	D. IESO System Impact Assessment	High		<i>Req'd for ancillary services & 10MW+</i>
5.03	Distribution System Infrastructure			
	A. New Line Expansion	High		-
	B. Reconductoring of Existing Feeder Trunk	High		-
	C. Site Distribution Transformer Upgrades	Medium		-
	D. Reconductoring of Branch/Tap	Medium		-
5.04	Protection, Monitoring, Metering and Telecom			
	A. Station Protection Upgrades	High		-
	B. Remote Monitoring	Medium		-
	C. Metering Upgrades	Low		-
	D. Transfer Trip	High		-
5.05	Distributor-Specific Criteria			
	A. Optional (Distributor to complete if needed)	TBD		-
	B. Optional (Distributor to complete if needed)	TBD		-
	C. Optional (Distributor to complete if needed)	TBD		-

Distributed Energy Resource (DER) Connection

Preliminary Consultation Report (PCR)

5.06 Distributor Overall Assessment of Connection Feasibility		
A. Anticipated Connection Capacity	Select	<i>Preliminary assessment by Distributor</i>
B. Anticipated Connection Complexity	Select	<i>Preliminary assessment by Distributor</i>

6. Additional Comments

6.01 Other Comments by Distributor

A. This section provides additional information not discussed in the prescribed fields above (e.g., potential flexible hosting capacity arrangement, alternate system configurations due to feeder switching, potential interconnection design suggestions, teleprotection and/or communication media, etc.).

Appendix 3

Generator Connection Assessment Review Form

12kW or Less

HALTON HILLS HYDRO INC.
Generator Connection Assessment Review Form
12 kW or less



1. Applicant's Contact Information (the party that will be contractually obligated for this generating facility)

Name _____
Company (if any) _____
Mailing Address _____
Phone Number (Main) _____ Cell _____
Fax Number _____ Email _____

2. Location of the Generation System

Street Address _____
Lot _____
Concession _____
County _____
Hydro Account Number (if any) _____

3. Applicant's Ownership Interest in the Generation System

Owner Co-owner Lease Other

4. Primary Intent of the Generation System

On-site Use of Power Net Metering Commercial power sales to a third party
 Participate in IESO or other government incentive program

5. Nameplate Rating, Electricity Use, production and Purchases

Nameplate rating of generation facility (ie: Total of all inverters AC output) _____ kW
(A) Anticipated annual electricity consumption of the facility or site _____ kWh/yr
(B) Anticipated annual electricity production of the generation system. _____ kWh/yr
(C) Anticipated annual electricity exports (i.e. (B) minus (A)) _____ kWh/yr

Value will be negative if there are no net sales to the distribution system.

6. Installing Contractor Information

Contractor Name _____
Mailing Address _____
Name of Contractor Contact _____
Phone Number (Main) _____ Cell _____
Fax Number _____ Email _____

7. Requested In-Service Date _____

8. Provide One-Line Schematic Diagram of the System:

Schematic is attached

Number of Pages _____

HALTON HILLS HYDRO INC.
Generator Connection Assessment Review Form
12 kW or less



9. Generator Information (complete for each generator)

Manufacturer _____ Model No. _____

Version No. _____ Serial No. _____

Generation Type:

Single Phase Three Phase Synchronous Induction Inverter Other: _____

Primary Energy Source:

Renewable: _____ Type: _____

Eligible for IESO contract? Yes No IESO Reference No.: _____

Is this a Distributed Energy Resource: Exporting Non-Exporting

Non-Renewable _____ Type _____

NOTE: If there is more than one generator and/or inverter, attach an additional sheet describing each.

10. Site Plan Showing Location of the External Disconnect Switch (attach additional sheets as needed)

11. Metering Configuration and Connection

Parallel Series Direct

12. Design Requirements

a) Has the proposed distribution generation paralleling equipment been certified?

Yes No

b) If not certified, does the proposed distributed generator meet the operating limits defined in Halton Hills Hydro's DG Technical Specifications?

Yes No

HALTON HILLS HYDRO INC.
Generator Connection Assessment Review Form
12 kW or less



For items 13(a) and 13(b), if your answer is yes, please furnish details (e.g., copies of manufacturer's specifications). If your answer is no, it is recommended you contact the equipment manufacturer and determine the status.

Status of certification and compliance with operating limits where answer to 13 (a) and/or (b) is no.

c) Does the generator/ inverter employ under frequency protection?

Yes No

If yes, please state the under frequency trip set point: _____ Hz
Time delay until activation: _____ seconds
Capacity being tripped offline: _____ kW

13. Other Comments, Specifications and Exceptions (attach additional sheets if needed)

14. Applicant and Installer Signature

To the best of my knowledge, all the information provided in this Application Form is complete and correct.

Applicant Signature

Date (yyyy/mm/dd)

Installer

Date (yyyy/mm/dd)

15. Release of Personal Project Related Information (check applicable)

- I hereby grant Halton Hills Hydro Inc. permission to correspond with, meet, and release project related information to the installer of my project.
- I hereby request that once prepared, Halton Hills Hydro Inc. sends the Connection Cost Agreement, Offer to Connect, and Connection Agreement to my installer rather than myself.

Applicant Signature

Date (yyyy/mm/dd)

Please complete and return this form to Halton Hills Hydro Inc., Engineering Department.

Appendix 4

Connection Impact Assessment Application Form

Greater than 12kW up to 10MW



Connection Impact Assessment (CIA) Application

Engineering Department, Generation@haltonhillshydro.com, 519-853-3700 213

[Insert LDC
LOGO]

▶ ABOUT THIS FORM

This Connection Impact Assessment (CIA) application is to be completed by any proponent interested in connecting a Distributed Energy Resources (DER) with a project size over 12 kilowatts (kW) to Halton Hills Hydro Inc. This includes DER applying for a new CIA or for revision(s) to their original CIA. This form expresses an intent to enter into an agreement between Halton Hills Hydro Inc. and the customer (or host customer* for non-exporting projects) for completion of a CIA associated with connecting a DER to the Halton Hills Hydro Inc. distribution grid. The CIA Application shall be part of the required servicing (electrical installation, maintenance, and operating) agreements between **Halton Hills Hydro Inc.** and the proponent. Through this process, **Halton Hills Hydro Inc.** will be the proponent's contact with the transmission system provider (e.g. Hydro One Networks Inc.) and, if necessary, the provincial market operator, namely, the Independent Electricity System Operator (IESO).

*For non-exporting projects, the term "host customer" refers to the owner of the load facility. The term "DER owner" refers to the owner of the DER facility.

Emergency Backup Generators should use the Emergency Backup Generation Application Form available at: <https://haltonhillshydro.com/for-business/conditions-of-service/>.

TECHNICAL REQUIREMENTS

- ▶ For technical requirements of **Halton Hills Hydro Inc for connecting** DER projects, refer to the "DER Technical Interconnection Requirements Interconnections at Voltages 50kV and Below", available at: <https://haltonhillshydro.com/for-business/renewable-generation/>.

SUBMISSION INSTRUCTIONS

Please return the completed form, fees and other required documents by mail to:

- ▶ Halton Hills Hydro Inc.
Attn: Engineering Department
Generation Connection Application
43 Alice Street
Acton, Ontario. L7J 2A9

IMPORTANT NOTES

- ▶
- An engineering stamp and all red box fields (on electronic version of form) are mandatory. Incomplete applications may be returned by **Halton Hills Hydro Inc** and will result in delays in processing your application. Click the "Validate Form" button on the top right of this page to ensure all required information is filled. If any of the required fields are not applicable to your project, type "N/A" in any required text field or "0" in any required numerical field
 - **Halton Hills Hydro Inc** specific requirements and notes are found in Sections S and T, respectively
 - Applicants are cautioned NOT to incur major expenses until **Halton Hills Hydro Inc** approves to connect the proposed DER facility.
 - All technical submissions (CIA Application, Single Line Diagrams, etc.) must be signed, dated and sealed by a licensed Ontario Professional Engineer (P.Eng.).
 - The proponent will pay for the CIA according to the **Halton Hills Hydro Inc** CIA Fee Schedule.





- The siting restrictions in O. Reg. 274/18 which were administered by electricity distributors such as **Halton Hills Hydro Inc** have been replaced by amendments to the Planning Act (Ontario) that puts siting and planning requirements for renewable DER facilities under municipal oversight. It is recommended that you discuss municipal permitting and approvals requirements with the planning department in the municipality where your DER project is located before you proceed.

▶ SECTION A: APPLICATION INFORMATION

Engineering Stamp <input type="text"/>	Application Type <i>choose one</i> <input type="text"/>	Date <i>mm/dd/yyyy</i> <input type="text"/>
	Program Type/Purpose <i>choose one</i> <input type="text"/>	Program Type (additional details) <input type="text"/>
	Project Name <input type="text"/>	
	IESO Contract Number <i>F-XXXXXX-XXX-XXX-XXX</i> <input type="text"/>	IESO Reference Number <i>FIT-XXXXXX</i> <input type="text"/>

Ontario Corporate Number or Business Identification Number <input type="text"/>	Proposed In Service Date <i>mm/dd/yyyy</i> <input type="text"/>
--	--

If this project is a subdivision project, please complete the following fields:

Subdivision Project Name <input type="text"/>	Number of Lots <input type="text"/>
--	--

For certain application type selections, please complete the required fields:

Original CIA Project ID # *XX,XXX*

Revised Fields *list the fields that have changed from your previous application*

▶ SECTION B: PROJECT LOCATION

Address <input type="text"/>	
City / Town / Township <input type="text"/>	Postal Code <input type="text"/>
Lot Number(s) <input type="text"/>	Concession Number(s) <input type="text"/>





▶ SECTION C: CONTACT INFORMATION

CIA will be issued in the name of the host customer (load facility owner). All agreements (including CCA and DCA) are only made between **Halton Hills Hydro Inc** and the host customer. This section is strictly to gather contact information of some of the key contacts that are involved with the project.

Who is the single point of contact for this project?

Host Customer DER Owner (if different from host customer) Consultant

Please enter the following information about the **host customer** (load facility owner)

Contact Person

Company's Legal Name

Mailing Address *including postal code, P.O. Boxes and Rural Routes will not be accepted*

Work Telephone

Cell Phone

Fax Number

Email Address

Please enter the following information about the **DER owner** (if different from host customer)

Contact Person

Company's Legal Name

Mailing Address *including postal code, P.O. Boxes and Rural Routes will not be accepted*

Work Telephone

Cell Phone

Fax Number

Email Address

Please enter the following information about the **consultant**

Contact Person

Company's Legal Name

Mailing Address *including postal code, P.O. Boxes and Rural Routes will not be accepted*

Work Telephone

Cell Phone

Fax Number

Email Address





▶ SECTION D: CUSTOMER STATUS

Is there an existing **HHHI** account at the project location?

Yes No

Is the account holder aware of this application?

Yes No

Does your account fall within a residential-rate classification?

Yes No Do not Know

Existing Account Number

Account Holder Name

Does the account holder have an HST registration number?

Yes No

HST Number

▶ SECTION E: EXISTING DER

Are there existing DER at the point of common coupling (PCC)?

Yes No

Existing Project Number

Existing Project Size (kW)

Program Type For Existing DER *choose one*

DER type: Synchronous Induction Inverter based Other

For synchronous units	For induction units	For inverter based units
Min. power limit for stable operation <i>kW</i> <input type="text"/>	Direct axis sub-transient reactance, $X''d$ <i>pu</i> <input type="text"/>	Inverter rating <i>kVA</i> <input type="text"/>
Direct axis sub-transient reactance, $X''d$ <i>pu</i> <input type="text"/>	Direct axis transient reactance, $X'd$ <i>pu</i> <input type="text"/>	Maximum continuous power output <i>kW</i> <input type="text"/>
Direct axis transient reactance, $X'd$ <i>pu</i> <input type="text"/>	Total PF correction installed <i>kVAR</i> <input type="text"/>	
Direct axis synchronous reactance, X_d <i>pu</i> <input type="text"/>		
Zero sequence reactance, X_0 <i>pu</i> <input type="text"/>		





▶ SECTION F: PROJECT INFORMATION

Station Name *(optional to leave blank for behind the meter projects)*

Fuel/Energy Type *select all that apply*

Feeder *(optional to leave blank for behind the meter projects)*

Feeder Voltage (kV) *(optional to leave blank for behind the meter projects)*

Project Size (kW) *total maximum output capacity*

Equipment Capacity (kVA) *total equipment nameplate rating*

Type of Connection

Single Phase

Three Phase

If this is a solar project, please answer the following questions:

Mounting Type *select one*

If this is a water project, please answer the following questions:

Is your generation facility located on provincial Crown or federally-regulated lands?

Yes

No

Is water your primary energy source?

Yes

No

▶ SECTION G: STATION SERVICE LOAD INFORMATION

The host customer's station service load details

If there is an existing account at the project location, populating the fields in Section G is [optional or required] for Halton Hills Hydro Inc. Ensure selection below matches with this note.

Required

Optional

Maximum Demand of Station Service Load of DER *kW*

Average Monthly Consumption *kWh*





▶ SECTION H: CONNECTION INFORMATION

On a cut-out from the *Halton Hills Hydro Inc* DOM (Distribution Operating Map), or a site plan if a DOM is not made available by the LDC, provide the location of the generation facility with proposed line routings for connection to *Halton Hills Hydro Inc's* distribution system. It should identify the Point of Expansion (POE), the Point of Common Coupling (PCC), the location of the generation facility, and (if applicable) the route of the new line between the generation facility and the POE (ie. on private property or public road/right-of-way). This is not required for existing load customers that are connecting a non-exporting generation, net metering generation or energy storage system behind their existing metered connection point. Please see "Appendix A" for a visual representation of POE and PCC.

DOM Drawing/Sketch Number

DOM Revision Number

Please provide an SLD of the Generator's facilities, including the PCC, transformer and connecting station, feeder, and supply voltage.

SLD Drawing/Sketch Number

SLD Revision Number

POE Latitude *degree decimal format*

POE Longitude *degree decimal format*

PCC Latitude *degree decimal format*

PCC Longitude *degree decimal format*

Generation Facility Latitude *degree decimal format*

Generation Facility Longitude *degree decimal format*

Length of Line from POE to PCC *km*

Length of Line from PCC to Generation Facility *km*

Important: The line between the PCC and the Generation Facility must NOT be shared with any other DER owner (refer to Appendix A).

Conductor Type/Size *for the line between the PCC and the Generation Facility*

Generator Fault Contribution *with fault location at the PCC*

IMPORTANT NOTES:

If this project requires line expansion work between the POE and PCC, *Halton Hills Hydro Inc* will provide a cost estimate to construct any line located on public road right-of-way. The cost estimate will include a breakdown of uncontestable work (i.e. overbuild to existing line) that can only be performed by *Halton Hills Hydro Inc*, as well as contestable work (i.e. new construction/green-field) that may be performed by the Generator, their contractor or *Halton Hills Hydro Inc*. The design of uncontestable and contestable work shall conform to *Halton Hills Hydro Inc* specifications).

For Generator-owned line, the Generator may apply to construct the line on existing *Halton Hills Hydro Inc*-owned poles. This is known as an application for Joint Use (JU) of poles. If the application is accepted, *Halton Hills Hydro Inc* will provide the Generator with information on initial connection costs, annual pole-space rental and emergency service (ES) fees, and required JU & ES Agreements.





▶ SECTION I: ENERGY STORAGE OR UPS

Please complete the following section if your project includes energy storage.

Number of Units

Inverter Unit Size *enter zero if inverter is shared with generation unit(s)*

Energy Storage Unit Size *kWh*

Total Energy Storage Size *kWh*

Energy Storage Facility Control Strategy

- Peak Shaving
- Dynamic VAR Support
- Frequency Support
- Other

Please submit a detailed description of the control strategy according to the templates in Appendix B. *Halton Hills Hydro Inc* reserves the right to modify the control strategy as part of its Detailed Technical Connection Assessment.

▶ SECTION J: NON-EXPORTING/PEAK SHAVING

Please complete the following section if this is a non-exporting or peak shaving project

Operating Mode

- Parallel
- Non-Parallel

Transition Type

- Closed *"make before break"*
- Open *"break before make"*

Time that generator remains parallel to grid *closed transition only, ms*

For non-parallel non-exporting, SCADA monitoring and Gross Load Billing (GLB) may apply. For non-exporting generation facilities, please attach a schedule of the forecasted maximum generation output (as a function of loading of the facility). At a minimum, include the forecasted generation output information (i.e. Watts and VARs) during the minimum and maximum of the load facility to which the non-exporting generator is connecting (see Appendix C for template)





SECTION K: DER CHARACTERISTICS

For facilities with multiple generators: If your generators have different characteristics, please use the "Add Page" button and provide the characteristics for each generator on the additional pages.

DER type: Synchronous Induction Inverter based Other

Number of Generating Units Rated Capacity of Each Unit kW kVA DER Output Voltage in kV

Manufacturer Type or Model Number

If Power Conversion Type is "Other", please provide values equivalent to a Synchronous or Induction type generator.

Maximum Starting In-rush Current multiple of full load current, pu Generator Winding Connection Delta Star

Neutral Grounding Method for star winding connection only Impedance R in ohms Impedance X in ohms

Limits of range of reactive power at the machine output:

Lagging over-excited, kVAR Lagging Power Factor Leading under-excited, kVAR Leading Power Factor

Limits of range of reactive power at the PCC:

Lagging over-excited, kVAR Lagging Power Factor Leading under-excited, kVAR Leading Power Factor

For synchronous units	For induction units
Nominal Machine Voltage $kV(LL)$ <input type="text"/>	Nominal Machine Voltage $kV(LL)$ <input type="text"/>
Unsaturated Reactance $kVA Base$ <input type="text"/>	Unsaturated Reactance $kVA Base$ <input type="text"/>
Unsaturated Reactance $kV Base$ <input type="text"/>	Unsaturated Reactance $kV Base$ <input type="text"/>
Direct Axis Subtransient Reactance, $X_d'' pu$ <input type="text"/>	Direct Axis Subtransient Reactance, $X_d'' pu$ <input type="text"/>
Direct Axis Transient Reactance, $X_d' pu$ <input type="text"/>	
Direct Axis Synchronous Reactance, $X_d pu$ <input type="text"/>	
Subtransient Time, $T_d'' ms$ <input type="text"/>	
Zero Sequence Reactance, $X_0 pu$ <input type="text"/>	





SECTION L: INTERFACE TRANSFORMER

The transformer connecting to the **Halton Hills Hydro Inc** distribution system

Transformer Ownership

Customer **Halton Hills Hydro Inc**

Transformer Rating *KVA*

Transformer Type

Single Phase

Three Phase

Nominal Voltage of High Voltage Winding *kV*

Nominal Voltage of Low Voltage Winding *kV*

Impedance Base (if different than ratings above)

kVA Base

kV Base

Impedance (R) *pu*

Impedance (X) *pu*

OR

Impedance (Z%) %

High Voltage Winding Connection

Delta

Star

High Voltage Grounding Method *for star winding connection only*

Solid

Ungrounded

Impedance

Star Impedance R *in ohms*

Star Impedance X *in ohms*

Low Voltage Winding Connection

Delta

Star

Low Voltage Grounding Method *for star winding connection only*

Solid

Ungrounded

Impedance

Star Impedance R *in ohms*

Star Impedance X *in ohms*

Notes

The term "High Voltage" refers to the connection voltage to **Halton Hills Hydro Inc's** distribution system and "Low Voltage" refers to the generation or any other intermediate voltage.

Providing a photo of transformer equipment along with this application may help expedite your application.





SECTION M: INTERMEDIATE TRANSFORMER

Transformer between the interface transformer and DER

Please complete the following section if your project includes an intermediate transformer.

Do you intend to install an intermediate transformer?

Yes No

Transformer Rating *kVA*

Transformer Type

Single Phase Three Phase

Nominal Voltage of High Voltage Winding *kV*

Nominal Voltage of Low Voltage Winding *kV*

Impedance

kVA Base

kV Base

Impedance R *pu*

Impedance X *pu*

High Voltage Winding Connection

Delta Star

High Voltage Grounding Method *for star winding connection only*

Solid Ungrounded Impedance

Star Impedance R *in ohms*

Star Impedance X *in ohms*

Low Voltage Winding Connection

Delta Star

Low Voltage Grounding Method *for star winding connection only*

Solid Ungrounded Impedance

Star Impedance R *in ohms*

Star Impedance X *in ohms*

Notes:

The term "High Voltage" refers to the connection voltage to *Halton Hills Hydro Inc's* distribution system and "Low Voltage" refers to the generation or any other intermediate voltage.

SECTION N: HIGH-VOLTAGE GROUNDING TRANSFORMER

Please complete the following section if your project includes a high-voltage grounding transformer.

Do you have a high-voltage grounding transformer?

Yes No

Transformer Type *select one*

Zig-Zag Star-Delta

Zero Sequence Impedance (Z0) R *ohms*

Zero Sequence Impedance (Z0) X *ohms*





▶ SECTION O: SUBMISSION CHECKLIST

Please ensure the following items are completed prior to submission. Your application may not be processed if any part is omitted or incomplete:

- Payment in full including applicable taxes (by cheque payable to “Halton Hills Hydro Inc”)
- Completed Form B stamped by a Professional Engineer
- Signed Study Agreement (original signature is required)
- Single Line Diagram (SLD) of the Generator’s facilities, must be stamped by a Professional Engineer
- Protection Philosophy
- Distribution Operating Map (DOM) and/or Site Plan *(not required for existing load customers that are connecting a non-exporting generation, net metering generation or energy storage system behind their existing metered connection point)*
- Non-exporting Generation Facility’s load and generation schedules (if applicable)
- Non-exporting Generation Facility’s mode of operation (if applicable)
- Energy Storage Facility operating strategy description an parameters (if applicable)
- Emergency Backup Generation Facility’s mode of operation (if applicable)

▶ SECTION P: CIA APPLICATION FEE CHECKLIST

Please ensure the following items are completed prior to submission. Your application will not be processed if any part is omitted or incomplete. Check all that apply:

- Applicable CIA Fee**
See the [Connection Impact Assessment Fee Schedule](#) on our website for costs. Please enter the amount from the fee schedule. \$ +HST
- Transmission Customer Impact Assessment (TxCIA) Fee (if applicable)**
A TxCIA is also required if the total nameplate generation of the project is greater than 10MW. \$ +HST
- IESO System Impact Assessment (SIA) Fee (if applicable)**
An SIA deposit is required if the total nameplate generation of the project is greater than 10MW. The total cost of the SIA will be Trued Up/Down upon the receipt of the SIA from the IESO.
See the [IESO’s SIA Application](#) for costs. \$





▶ SECTION Q: ATTACHMENTS

Attached Documents / Drawings

Item #	Description	Document #	# of Pages

▶ SECTION R: NOTES





▶ **SECTION S: Halton Hills Hydro Inc Specific Required Fields**

This section contains specific information that is required by Halton Hills Hydro Inc. Please read Section T notes regarding this section if you need further details.

What is the barcode of the nearest pole serving the project location?

Halton Hills Hydro Inc Account Number *if transformer is owned by Halton Hills Hydro Inc*

▶ **SECTION T: Halton Hills Hydro Inc Specific Additional Notes**

Section A: no additional notes

Section B: no additional notes

Section C: no additional notes

Section D: no additional notes

Section E: no additional notes

Section F: no additional notes

Section G: no additional notes

Section H: no additional notes

Section I: no additional notes

Section J: no additional notes

Section K: no additional notes

Section L: At the Generator’s expense, and if requested, Halton Hills Hydro Inc may provide transformation up to a maximum of 500 kVA three-phase, as described in the Halton Hills Hydro Inc Conditions of Service (Section 3.5 item C.4). **Section M:** no additional notes

Section N: no additional notes

Section O: for new DER site, Distribution Operating Map (DOM) is required by Halton Hills Hydro Inc in addition to Site Plan

Section P: When there is an upstream LDC, an additional fee will be required for costs associated with this LDC’s CIA.

Section Q: no additional notes

Section R: no additional notes

Section S: - For question: "What is the barcode of the nearest pole serving the project location?", this is only applicable if you choose "No" to question: "Is there an existing Halton Hills Hydro Inc account at the project location?" in Section D

- For question: "Halton Hills Hydro Inc Account Number (if transformer is owned by Halton Hills Hydro Inc)", this is only applicable if you answer "Halton Hills Hydro Inc" to question: "Transformer Ownership" in Section L.





▶ APPENDIX A - FIGURES & DIAGRAMS

Figure A1: Where There is No New Halton Hills Hydro Inc. Owned Line Expansion

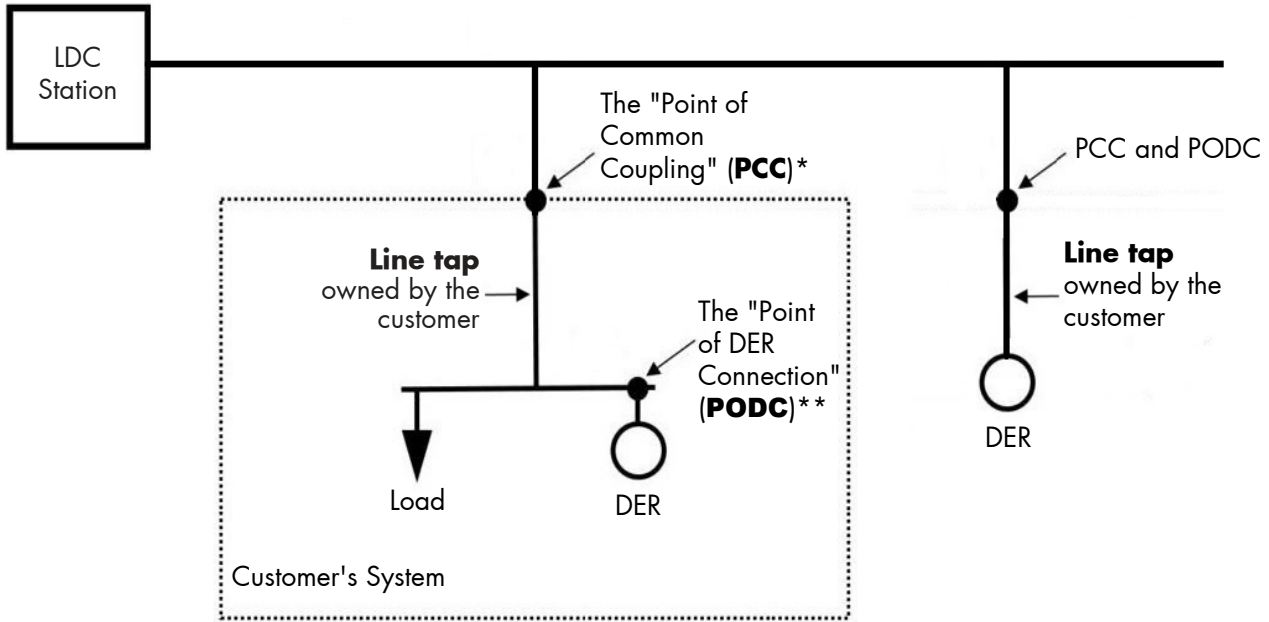

*PCC: the point where the customer facility connects to the LDC owned system

**PODC: the point where the DER unit(s)'s interconnection system connects the DER unit(s) to the DER facility.

Figure A2: Where There is a New Halton Hills Hydro Inc. Owned Line Expansion

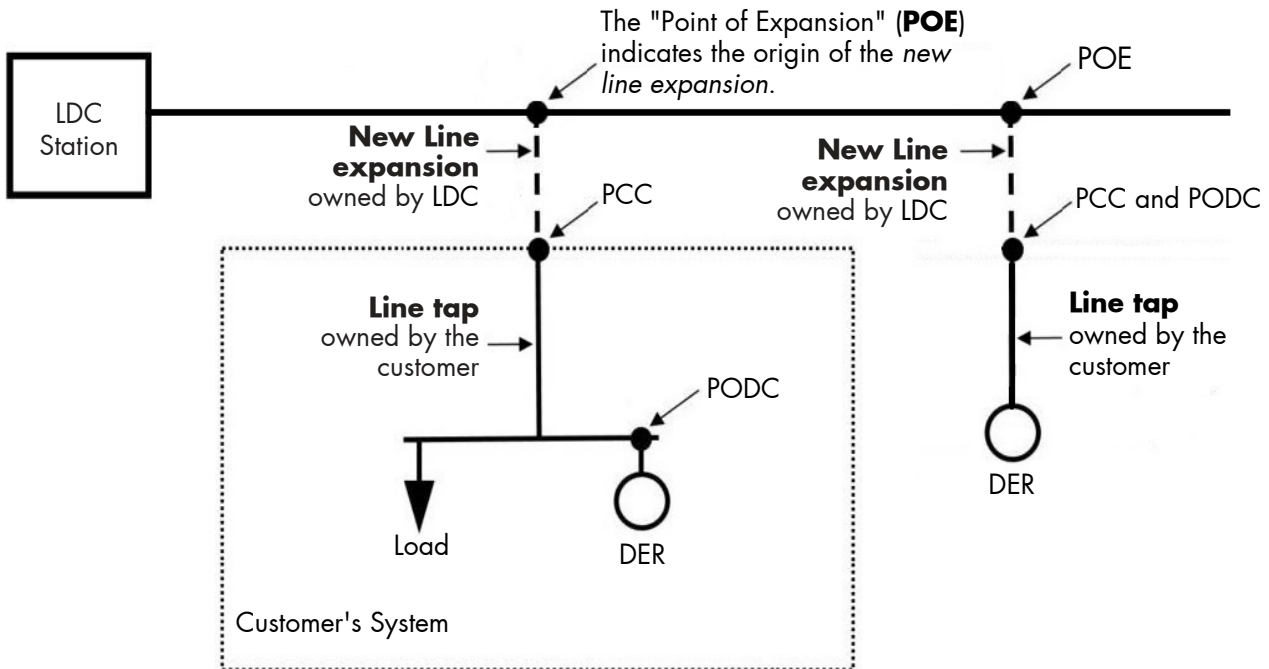



▶ APPENDIX B - MINIMUM CONTROL STRATEGY INFORMATION FOR ENERGY STORAGE FACILITIES OR OTHER TECHNOLOGIES

Figure B1: Peak Shaving

Peak Shaving			
Description of Control Strategy			
When Operating as a Load			
Switch In Time	Switch Out Time	Load kW (peak)	Load kVAR (peak, leading/lagging)
When Operating as a Generator			
Switch In Time	Switch Out Time	Generation kW (peak)	Generation kVAR (peak, leading/lagging)

Figure B2: Dynamic VAR Support

Dynamic VAR Support			
Description of Control Strategy			
Switch In Condition	Switch Out Condition	Generation kW (peak)	Generation kVAR (peak, leading/lagging)

Figure B3: Frequency Support

Frequency Support			
Description of Control Strategy			
Switch In Condition	Switch Out Condition	Generation kW (peak)	Generation kVAR (peak, leading/lagging)

Figure B4: Other Control Strategies

Other	
Description of Control Strategy and Relevant Operating Parameters	





▶ APPENDIX C - NON-EXPORTING FIGURES

Figure C1: Example Schedule With Minimum Information Required for Non-exporting Projects

	Load of Facility (kW)	Load of Facility (kVAR, lead or lag)	Generation Output (kW)	Generation Output (kVAR, lead or lag)
Minimum Load				
Maximum Load				



Appendix 5

ESA Electrical Guidelines for Inverter-Based Micro Generating Facilities 10kW and Smaller

(Please check with ESA to ensure you have the most up to date guidelines)

ELECTRICAL GUIDELINES FOR
**Inverter-Based
Micro-Generating Facility**
(10KW and Smaller)



Electrical Guidelines for Inverter-Based Micro Generation Facilities

1. Scope
2. Overview
 - 2.1 Types of Distributed Generation
 - 2.2 Typical Inverter-Based Micro Generation System
3. Definitions
4. Parallel Generation Projects
 - 4.1 Planning and Installation
 - 4.2 Electrical Inspection Process
5. Other Sources of Information

1. SCOPE

This guideline is intended to serve a very specific need for inverter based micro generation used for the following application:

1. Load displacement

The scope of the guideline deals only with the installation of inverter-based micro generation facilities, 10kW or smaller. For larger generator units, greater than 10kW refer to Spec-005-Process Guideline for the Installation of Parallel Generating Systems (Greater than 10kW). For these larger installations, plans will have to be submitted to the Local Distribution Company and the Electrical Safety Authority for review and approval before any installation work begins.

This guideline is in no way intended to be used as a substitute for the Ontario Electrical Safety Code. Omission of any requirements in the OESC, from this guideline, does not in any way affect the OESC, and these omitted requirements shall not be considered irrelevant. The Ontario Electrical Safety Code is law in Ontario, and as such defines the legal requirements for safe electrical installations, products, and equipment in Ontario.

2. OVERVIEW

Today many home, farm and small business owners are considering the installation of alternative forms of electricity generation (distributed generation) and connecting them to run in parallel with the Local Distribution Company (utility) electrical system. This may include the installation of small wind turbines, photovoltaic (solar) systems, micro-hydro turbines or fuel cells and Energy Storage Systems (ESS). These systems are intended to reduce the amount of power purchased and the time at which it is purchased from the local electricity distribution company and where they are powered from renewable sources such as wind, flowing water or sunlight they also provide environmental benefits.

The Ontario Power Authority has developed the Renewable Energy Program for the Province to encourage and promote greater use of renewable energy sources including wind, waterpower, renewable biomass, bio-gas, bio-fuel, landfill gas and solar for electricity generating projects that can be connected to a host facility, a distribution system or the IESO-Controlled Grid, in Ontario. The fundamental objective is to help facilitate the increased use in the Province of Renewable Generating Facilities and Energy Storage Systems (ESS) of varying sizes, technologies and configurations via a standardized, open and fair process.

Any system that produces even small amounts of electricity can be potentially dangerous, creating the possibility of electrocution and fire hazards. Improperly installed systems will create serious safety hazards to property owners, their friends, family, employees and local electric distribution company workers.

Before installing any type of distributed generation, whether it is stand-alone or connected to the grid, it is important to understand the safety requirements. The safety regulations, the codes and the associated safety technical standards can be confusing and difficult to understand for non-technical persons. This guideline is intended to simplify these and provide basic safety advice to home, farm and business owners who are considering the installation of Inverter-Based Micro generation systems.

This guideline is based on the requirements of the Electrical Safety Authority's Ontario Electrical Safety Code (OESC) and the Ontario Energy Board's Distribution System Code.

2.1 TYPES OF DISTRIBUTED GENERATION

The Distribution System Code describes four categories of distributed generation.

Generator Classification	Rating
Micro	< 10 kW
Small	(a) ≤ 500 kW connected on distribution system voltage < 15 kV (b) < 1 MW connected on distribution system voltage > 15 kV
Mid-Sized	(a) > 500 kW connected on distribution system voltage < 15 kV (b) > 1 MW < 10 MW connected on distribution system voltage > 15 kV
Large	> 10 MW

2.2 TYPICAL INVERTER-BASED MICRO GENERATION SYSTEM

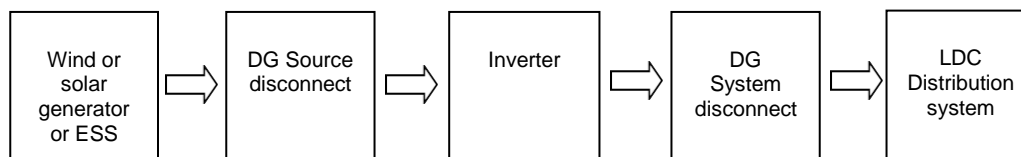

Diagram 1 - Block diagram of basic DG system

3. DEFINITIONS

Approved Electrical Equipment: Equipment that is approved in accordance with the OESC and bears product approval markings for use in Ontario. The presence of approval markings confirms to the user that the equipment is in compliance with the Ontario regulations (Refer to ESA website <https://www.esasafe.com/electricalproducts/marks> for recognized approval marks for products approved for use in Ontario).

Combiner box: A box used in solar installations to combine the multiple photovoltaic arrays source circuits to produce one circuit. It often contains generator overcurrent devices.

Disconnecting means: A device, group of devices, or other means whereby the conductors of a circuit can be disconnected from their source of supply. Examples of disconnecting means are a switch or a circuit breaker.

Distributed Generator (DG): Electric generation facilities connected to a Distribution System through a point of common coupling (PCC).

Generator: Equipment that produces electric power. Examples of inverter-based micro generators are wind turbine and photovoltaic array, both of which produce Direct Current (DC) power. Energy Storage Systems (ESS) the output of which are interconnected to a supply authority system are also examples of generators for the purpose of this specification.

DG Source Disconnect: Disconnecting means to disconnect the distributed generation source from the equipment that it supplies.

DG System Disconnect (Utility Disconnect): Disconnecting means to disconnect the distributed generator from the utility distribution system. This disconnect ensures the safety of electrical utility workers by allowing them to disconnect the generator from the utility system in case they have to service or repair the electrical supply to your home, farm or business. Also referred to as “utility disconnect”.

Distribution Panel: The distribution panel contains overcurrent devices and distributes electricity to the various electrical circuits and equipment in your home, farm or business.

Distribution System Code (DSC): Sets out the minimum conditions that an electricity distributor must meet in carrying out its obligations, the DSC is established and approved by the Ontario Energy Board (OEB). All licensed electricity distributors in Ontario must comply with the provisions of the DSC as a condition of their license.

Inverter: A device that converts direct current (DC) electricity into alternating current (AC) electricity. It can also be referred to as power conversion equipment.

Stand-Alone Inverter: An inverter that operates only in stand-alone mode and thus contains no facility to synchronise its output energy to a Utility Distribution.

Utility-interconnected inverter: An inverter that is able to operate in grid parallel mode with the utility distribution facility. Thus contains provision for anti-islanding and for synchronizing distributed generation output voltage, phase and frequency to the utility distribution. Also known as “Grid Connected”, or “Grid Tie Inverter”. There are two types of utility-interconnected inverter; a Grid Dependant and a Grid Interactive.

Grid Dependent Inverter: An inverter that is able to operate in parallel to the distribution system and in order to operate there must be power available from the electric utility’s electricity grid. Loss of power from the grid will initiate a shutdown of the inverter to prevent islanding. Distributed generation systems using a grid dependent inverter will not provide back-up power during a utility power outage.

Grid-interactive Inverter: An inverter that is able to operate in both stand-alone and grid-parallel modes according to the availability of the distribution system. It can be considered as an uninterruptible power supply that is also able to operate in grid-parallel mode. This type of inverter initiates grid-parallel operation.

Energy storage systems (ESS) — equipment or systems that receive electrical energy and provide a means to store that energy in some form for later use in order to supply electrical energy when needed.

Energy storage systems, self-contained — energy storage systems where the components such as cells, batteries, or modules and any necessary controls, and ventilation, illumination, fire-suppression, or alarm systems are assembled, installed, and packaged in a single energy storage container or unit.

Energy storage systems, other — energy storage systems that are not self-contained but are individual devices assembled as a system.

Island: A condition in which a portion of the utility distribution system is energized by a Distributed Generator while that portion of the utility distribution system is electrically separated from the rest of the utility distribution system.

Anti-islanding: The distributed generator system shall cease to energize the utility distribution system after the formation of an unintentional island (i.e. for inverter based generations the inverter shall meet the anti-islanding requirements of CSA C22.2 No. 107.1).

Local Distribution Company (LDC): The distribution of electricity to end use customers is carried out by Ontario's local electrical utilities or LDCs. These utilities are responsible for maintaining their community's network of distribution wires. Also referred to as "Supply Authority".

Micro-embedded generation facility: A generation facility connected on the customer side of the electricity meter that produces 10kW of electricity or less.

Net metering connection: The installation includes one revenue load meter. The generator is connected beyond the load meter, the generated power is used for load displacement; the project is a **Micro-embedded Load Displacement project**. Refer to Diagram A.

Ontario Electrical Safety Code (OESC): Provides the standards for the safe installation of all temporary and permanent electrical wiring and equipment. The OESC applies to all homes, businesses, farms and industry in Ontario. The Ontario Electrical Safety Code is law in Ontario, and as such defines the legal requirements for safe electrical installations and products/equipment in Ontario

Overcurrent Device: A device capable of automatically opening an electric circuit, under both predetermined overload and short-circuit conditions, either by fusing of metal or by electromechanical means (a fuse or circuit breaker). An approved fuse or circuit breaker is required to protect people and the electrical system from a short circuit or overload failures. This is an important safety device.

Service box: An approved assembly consisting of an enclosure that can be locked or sealed, containing either fuses and a switch, or a circuit breaker, and of such design that it is possible to operate either the switch or circuit breaker to the open position by manual means when the box is closed.

4. PARALLEL GENERATION PROJECTS

4.1 PLANNING AND INSTALLATION

Before you begin any installation work or make any commitments to purchase equipment or have equipment installed, it is very important that you review all relevant documents, guidelines and available information.

A. Information to be gathered and reviewed:

- 1. Review the Independent Electricity System Operator website <http://www.ieso.ca/>**
- 2. Review the Ontario Energy Board's Distribution System Code (Appendix F)**
- 3. Review the OESC and these Electrical Safety Authority Guidelines**
Be sure to review and understand the Electrical Safety Authority guidelines, including the requirements for electrical inspection and approval. An "Application for Inspection" is required.
- 4. Some questions to consider are:**
 - Is a service upgrade required to accommodate the installation of an alternative generator?
 - Are there any other special technical requirements?
 - Discuss with your LDC
- 5. Check for any local bylaw or permit requirements.**
In addition to ensuring that you understand the electrical safety requirements you should also check with you local municipality, township or county about any by-law or permit requirements that might apply depending on the type of installation.

B. Proceeding with the Installation:

1. Submit a connection request form to your LDC

Refer to your LDC website or contact them for information regarding their connection process for renewable energy and energy storage projects.

2. Select Your Electrical Contractor

Prior to hiring an Electrical Contractor, confirm that they are licensed by the Electrical Contractor Registration Agency of the Electrical Safety Authority (ECRA/ESA)

It is also recommended that you ensure that:

- They can provide references
- They are prepared to apply for the necessary Notification of work if the person you are considering for the installation tells you that an electrical inspection is not required or suggests that you apply for the inspection on his or her behalf, find someone else to do the work.
- They will provide a written estimate of the cost of the work.
- You ask about the amount of experience the electrical contractor has installing alternative generation systems.
- If the electrical contractor is providing the electrical equipment as part of the installation ensure that they are providing and installing approved equipment.
- They will provide you with a copy of the "Certificate". The Local Distribution Company will require a copy of the "Certificate" before they will finalize the connection agreement with you. You may

wish to hold back final payment until you get this certificate.

3. File a Completed Notification of work with the Electrical Safety Authority

Before beginning the electrical work (or within 48 hours), your electrical contractor must file Notification of work with the Electrical Safety Authority and pay the appropriate fees. For the installation of micro-generation systems the submission and approval of plans is not required. If you are the homeowner and you are doing the work (not recommended) you are responsible for filing the application for inspection.

1-877-ESA-SAFE (1-877-372-7233) || www.esasafe.com

An Electrical Inspector will inspect the installation to determine if it meets the requirements of the OESC.

If the installation meets the safety requirements of the OESC, then a “Connection Authorization” will be issued to the LDC and a “Certificate of Inspection” will be provided to the applicant (i.e.: owner/electrical contractor). These documents provide assurance that the installation was inspected by ESA, was found in compliance with the requirements of the OESC, and may be connected and used.

4. Finalize the connection agreement with the LDC

4.2 ELECTRICAL INSPECTION PROCESS

Before the generator can be connected to the electrical system it must be inspected and approved by the Electrical Safety Authority. The OESC requires a Notification of work to be submitted by the contractor doing the electrical installation. The inspection provides assurance that the installation meets the safety requirements of the OESC. The electrical inspection process does not include the inspection of the structural integrity of the roof, the windmill installation or other non-electrical infrastructure for the installed generator equipment.

In addition to the standard inspection process, to verify that the electrical work meets the OESC, the ESA will be reporting the following to the LDC:

1. The type of the renewable energy of the project (i.e.: solar, wind etc.).
2. The generator total kW capacity and the inverter maximum output kW capacity

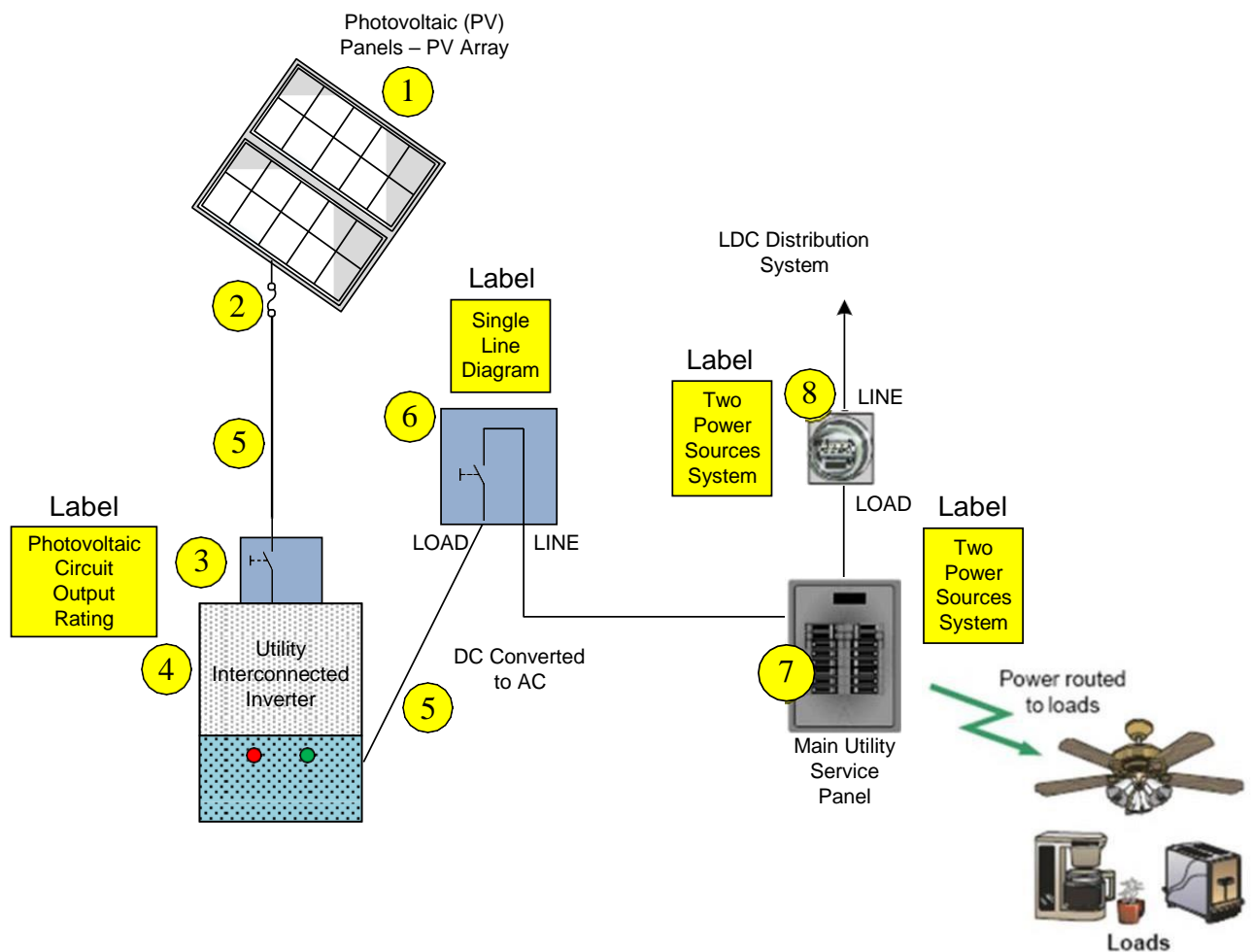

- 3.
4. **Diagram A: Net metering connection - Micro-embedded Load Displacement System**
5. **With reference to the above diagram, the Inspector will look for the applicable OESC requirements when inspecting the generation installation.**

All electrical devices and equipment shall be approved and bear accepted product approval markings for use in Ontario.

With reference to diagram A, the following is required according to the OESC:

1 Generator type and characteristics

The generator could be wind powered, photovoltaic, micro-hydro, etc. The Inspector will check the nameplate and note the generator electrical characteristics. Manufacturer specifications shall be made available to the inspector.

For Solar installations, flexible cords for extra-hard usage shall be permitted to interconnect modules within an array. If the combiner box is installed within the array, flexible cord shall be permitted to connect the array to the combiner box.

2 Overcurrent Device(s)

Where required by the OESC for protection of conductors and equipment from overcurrent (short circuit or overload). The rating and type shall be compliant with the OESC based on the generator nameplate ratings and the conductors and equipment.

For a Solar installation, the overcurrent devices may be located in the combiner box. The combiner box shall be permitted to be located on the roof.

3 Disconnecting Means – Generator or Distributed Generation (DG) Source

The disconnecting means shall be sized to safely disconnect the output of the generator unit. The OESC provides information on the sizing requirements. The disconnecting means shall have a label marked “DG SOURCE DISCONNECT”.

For solar installations, a permanent marking shall be provided at an accessible location at the disconnecting means for the photovoltaic output circuit specifying; rated operating current and voltage; rated open-circuit voltage; and rated short-circuit current.

Some Inverters units might have the disconnecting means built into the inverter unit. In that case, the label “DG SOURCE DISCONNECT” will be on the inverter unit. If this is the case a separate disconnecting means is not required.

If the inverter is an integral part of the generator, and the combined unit is approved, there is no DG SOURCE DISCONNECT required. For Micro-inverters plugged into the panels, no DG SOURCE DISCONNECT is required.

4 Utility Interconnected Inverter

An approved Utility Interconnected Inverter is required. The inverter shall bear a certification mark that indicates that the inverter meets the requirements of the Canadian Standards Association Standard CSA C22.2 #107.1. Field Evaluation shall not be accepted for “Utility Interconnected Inverter”. The Inspector will also check the nameplate and note the Inverter electrical characteristics.

The inverter shall bear a label stating “UTILITY-INTERCONNECTED” indicating it meets the standard for utility interconnected inverters.

5 Wiring Methods

Wiring shall be installed in accordance with requirements set out in Section 12 of the OESC.

All exposed installations including cables, conduits, connector, attachment plugs, etc. will be approved for outdoor installations and marked accordingly.

For Solar installations, refer also to Section 50 for additional requirements. Permanent wiring methods identified in Section 12 shall be used to interconnect the inverter to the array.

6 Disconnecting Means — Distributed Generation (DG) System (Utility disconnect)

The inspector will verify that a disconnecting means (intended to prevent back feed into the utility system) is installed. Recommended location of the disconnecting means is adjacent to the utility meter(s). The disconnecting means shall be properly sized to disconnect the electrical output from the inverter, have provision for being locked in the open position and will simultaneously disconnect all ungrounded conductors of the distributed generator from the distribution supply system.

NOTE: Verify if your LDC requires contact operation to be verified by direct visible means, and that the location of the utility disconnect meets the LDC's requirements.

The disconnecting means shall have a label marked "DG SYSTEM DISCONNECT – WARNING – TWO POWER SOURCES".

A single line diagram shall be posted at the disconnecting means. This single line diagram must be plainly and permanently marked, shows the switching arrangements, the location of the disconnecting means, the location and type of generator. The single line diagram should identify related components of the interconnected system, including switching arrangements, interlocks, isolation points, and their relative locations.

7 Load displacement systems shall be connected to a dedicated branch circuit in the host distribution panel

Load displacement projects are not required to make application to the IESO

Net Metering is an agreement between the LDC and a customer who generates electricity from renewable resources. The customer produces and consumes electricity, and may send surplus energy to the grid.

5. **OTHER SOURCES OF INFORMATION**

- Ontario Electrical Safety Code
- CSA C22.2 #107.1 General Use Power Supplies
- ULC/ORD-C1703-01 Flat Plate Photovoltaic Modules and Panels
- The Renewable Energy Handbook for Homeowners by William H. Kemp
- Smart Power; an urban guide to renewable energy and efficiency The Renewable Energy Handbook for Homeowners by William H. Kemp
- Distribution System Code published by OEB
- Standby Generators and Emergency Power Information By Ministry of Agriculture and Food
 - Generator Handbook
 - Generator fact sheets
 - <http://www.omafra.gov.on.ca/english/engineer/energy.html>
- Electricity Generation Using Small Wind Turbines at Your Home or Farm, by S. Clarke of the Ministry of Agriculture
- CAN/CSA-C22.2 No. 257-06 Interconnecting Inverter-Based Micro-Distributed Resources to Distribution Systems
- The Kortright Centre for Conservation - environmental and renewable energy education and demonstration centre.

To file for a Notification of work call: **1-877-ESA-SAFE (372-7233)**

www.esasafe.com

Appendix 6

Metering Configurations

METERING CONFIGURATIONS

Indirectly Connected in Series (not permitted under microFIT or FIT)
Connection occurs on the load side of the customers load meter.

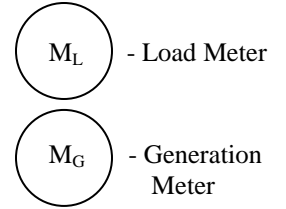
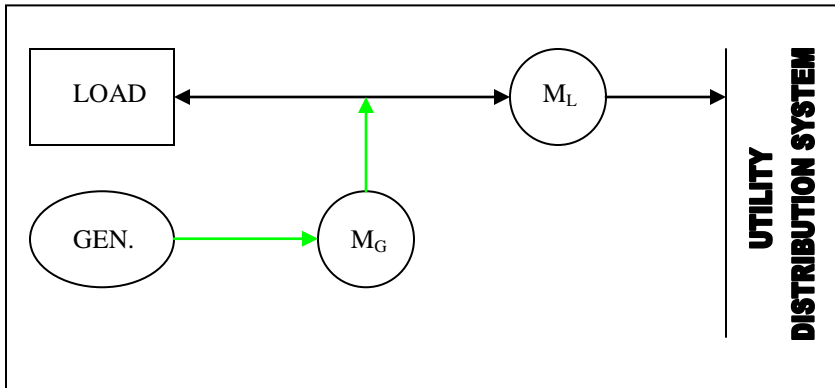

Indirectly Connected in Parallel
Connection occurs on the line side of the customers load meter.

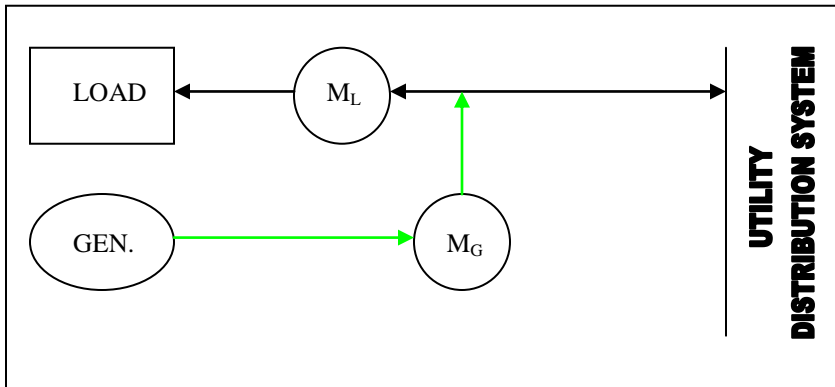

Directly Connected
Connection is made directly to the utilities distribution system.

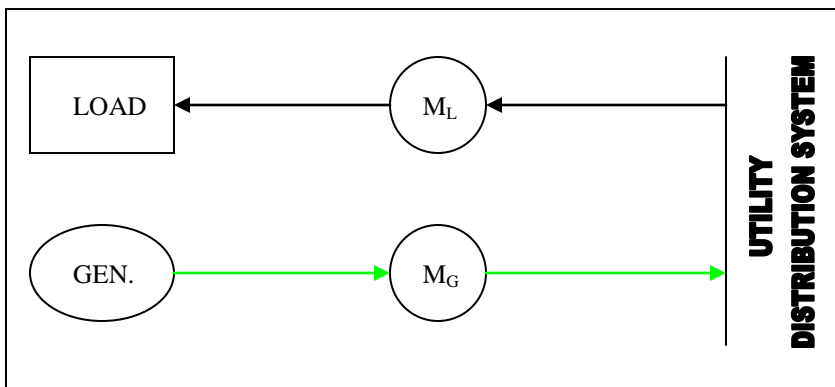

For advantages and disadvantages of each type of connection please visit the Independent System Electricity Operators FIT program website at <http://fit.powerauthority.on.ca/>.

Appendix 7

Commissioning and Equipment Verification Report

Prior to an applicants distributed generation project being connected to Halton Hills Hydro's (HHH's) distribution system, the applicant in working with HHH must complete Commissioning and Equipment Verification Report (Report) verifying the equipment is approved, tested with all A/C output inverters (or other A/C output devices) active, and suitable for connection.

The Applicant should submit their Commissioning Plan to HHH at least 5 business days prior to the commissioning test date. The applicant should note that HHH requires this Report to be signed and sealed by a Professional Engineer registered with the Professional Engineers of Ontario on the applicant's behalf.

In addition to testing required on the part of the Applicant to satisfy other regulatory agencies, HHH requires that Commissioning and Verification tests be performed per CSA C22.3 No. 9-08 "Interconnection of Distributed Resources and Electricity Supply Systems", IEEE 1547 "Standard for Interconnecting of Distributed Resources with Electric Supply Systems" and The OEB Distribution System Code Appendix F.2 "Technical Requirements".

This Report applies to distributed generation projects greater than 12kW. Field testing portions of this report shall be conducted by qualified individuals hired by the applicant.

Instructions for Completing this Report:

- The applicant shall contact HHH's Engineering Tech and present their Commissioning Plan at which time HHH's Engineering Tech shall fill in the grey areas of Section 1 "General Site Information" and Section 2 "Contact Information" as send this Report to the Applicant.
- The Applicant shall complete Section 1 "General Information" and Section 2 "Contact Information".
- During commissioning the Applicant will complete their portions of this Report after which HHH will complete their portions of the same Report.
- In Section 3 "Equipment Verification and Testing" the Applicant shall indicate a result of Pass, Fail, or N/A. Where a result of Fail or N/A is applied the Applicant shall provide notes as to the reason.
 - White area's are to be completed by the Applicant.
 - Grey area's are to be completed by HHH's Engineering Tech or an HHH representative.
- The Applicant shall record any deficiencies and resolutions of those deficiencies in Section 4 "Deficiencies and Resolutions". Where no deficiencies are found the Applicant shall check the box at the bottom of Section 4.
- HHH's Engineering Tech shall complete Section 5 "Electrical Safety, Site Access, and Agreements".
- The Applicants and their representative (P.Eng.) shall sign where indicated in Section 6 of this Report.
- HHH's Engineering Tech shall review the Report and once satisfied sign the Engineering Tech portion of Section 6 of this Report.

A copy of the completed Report shall be provided to the Applicant as well as filed in HHH's project file.

1	General Site Information	
Name of Applicant		
Name of Facility		
Proposed Energization Date		
HHH D.G. Designation		
Transformer/ Distribution Station		
Feeder Name		

2	Contact Information	
	Applicant Contact	HHH Engineering Tech Contact
Name:		Name:
Title:		Title:
Tel. #:		Tel. #:
Fax #:		Fax #:
Email:		Email:

3	Equipment Verification and Testing (Applicant) (All inverters must be installed and working during commissioning tests)	
Results: P = Pass, F = Fail, N/A = Not Applicable		
Item to be Verified	Result	Notes
Confirm output voltage of generator is no less than 7% below and no greater than 4% above nominal voltage (CSA C235-83, table 3) with clearing times per CSA C22.3 No 9-08. This shall be confirmed by monitoring voltage for 5 minutes with all inverters active.		
Check Phase Rotation (Generator)		
Under Voltage Protection (IEEE 27) working		
Over Voltage Protection (IEEE 59) working		
Confirm frequency is operating in the range of 59.4Hz to 60.6Hz (CSA C22.3 No 9-08). This shall be confirmed by monitoring frequency for 5 minutes with all inverters active.		
Under Frequency Protection (IEEE 81/O) working with clearing times per CSA C22.3 No 9-08		
Over Frequency Protection (IEEE 81/U) working with clearing times per CSA C22.3 No 9-08		
Maximum Harmonic Current Distortion is per CSA C22.3 No 9-08		
Power Factor per OEB DSC Appendix F.2, item 4		
All grounding is in accordance with the Ontario Electrical Safety Code at CSA C22.3 No 9-08		
Instrument Transformers are functioning within manufacturer tolerance (CT's/ PT's)		
Confirm Protective Relays/ Circuit Breakers are calibrated and functioning correctly.		
All Protective Schemes and interconnecting devices relating to loss of utility power function correctly		
Field installed power and control wiring compliant with specifications		

3	Equipment Verification and Testing Continued (Applicant) (All inverters must be installed and working during commissioning tests)	
Results: P = Pass, F = Fail, N/A = Not Applicable		
Item to be Verified	Result	Notes
Confirm Islanding Detection (ID, Anti-Islanding) functions and removes all generation sources from grid upon simulated utility power outage. This shall be confirmed by a field test once all inverters are actively outputting A/C voltage and current into the distribution system. Steady state production shall be monitored for 5 minutes. After 5 minutes the line side A/C switch will be opened for 1 minute, then closed. During the simulated utility outage the inverters output shall be monitored to ensure they do not produce power during the outage and also do not start producing power immediately when utility power is restored. Grid dependent inverters should not actively produce power until 5 minutes after A/C power is restored. After the inverters begin producing power, monitoring of voltage, current, and frequency shall continue for another 5 minutes.		
Monitoring Equipment that HHH has remote access to functions correctly (where applicable)		
Confirm Transfer Trip (where applicable): a) Ceases to energize the distribution system upon receiving a transfer trip signal, b) Ceases to energize the distribution system upon transfer trip communication loss.		
Inverter and related equipment is Certified to UL1741, IEEE 1547, and CSA Standards		
Ensure that all active sources of power production (ex. inverters) are on site and working (to be completed by an independent Professional Engineer hired by the applicant)		

3	Equipment Verification and Testing (HHH)	
Results: P = Pass, F = Fail, N/A = Not Applicable		
Item to be Verified	Result	Notes
Check Phase Rotation on Distribution System		
DG AC Disconnect is CSA/ ULC Approved, lockable, and accessible to HHH staff		
Meter base/ cabinet specified was installed		
ESA warning label "DG SYSTEM DISCONNECT" affixed to AC Disconnect		
ESA warning label "WARNING TWO POWER PARALLEL SYSTEM" affix to meter base/ cabinet.		
Inverter bares Certification Organizations emblem.		
Confirm that communication to HHH meter is working (may require office/ ODS assistance) Note: This check may occur following connection		
Check dial-in/ Ethernet connection to meter (if applicable) Note: This check may occur following connection		

3	Equipment Verification and Testing (Equipment Data)		
HHH	CT and PT Ratios for meter (400A and up):	CT Ratio: _____ PT Ratio: _____	
	Meter Reading after Commissioning Complete (if applicable):	_____ kWh	
Applicant	Customer Step-up Transformer Size (kVA):		Transformer Impedence:
	Transformer Manufacturer:		Manufactured Date:
	Transformer Serial Number:		
	Power Factor (>30kW, PF = ± 0.9):	o Leading _____	o Lagging _____
	Phase Rotation (from 0°):	R _____	W _____



4	Deficiencies and Resolutions	
	Deficiency	Resolution
1		
2		
3		
4		
5		
6		
7		
8		
	No Deficiencies were found at time of commissioning o (check)	



5	Electrical Safety, Site Access, and Agreements	
Item	Received (check)	Date (yyyy/mm/dd)
If required for commissioning tests, ESA Temporary Connection Authorization per OESC 2-014		
HHH has received keys to access meter (where applicable)		
Letter from a Professional Engineer that is signed and sealed stating that the equipment and installation meets CSA, ESA, and all other applicable industry Standards.		
HHH has received copies of Applicants own commissioning and testing reports		

6	Completion of Report and Acceptance Sign-off's	
<p>By signing this Report the Applicant and their Representative acknowledges that all required verifications on their part have been completed and that the Applicants generation facility meets or exceeds the minimum industry design Standards, Regulations, and Laws for such a facility connected to a distribution system in Ontario.</p> <p>The applicant has submitted to HHH copies of their own commissioning and testing reports that may be included with this or separate from this Report.</p>	<p>_____</p> <p>Signature of Applicants Representative (must be a P.Eng.)</p> <p>Name (Print): _____</p> <p>Date (yyyy/mm/dd): _____</p>	
	<p>_____</p> <p>Applicant's Signature</p> <p>Date (yyyy/mm/dd): _____</p>	
<p>HHH's Engineering Tech has reviewed the above Report and found the results and information provided to be acceptable to HHH. The project may move forward towards connection subject to all approvals/ documentation being in order prior to connection.</p>	<p>_____</p> <p>Signature of HHH Engineering Tech</p> <p>Name (Print): _____</p> <p>Title: _____</p> <p>Date (yyyy/mm/dd): _____</p>	
	<p>_____</p>	

Appendix 8

Connection Agreements

1. 12kW or Less

2. Above 12kW (Small and Mid-Sized)

Halton Hills Hydro Inc. Micro-Embedded Net Metered Generation Facility Connection Agreement

In consideration of Halton Hills Hydro Inc. (HHHI) agreeing to allow you to connect your 12 kW name-plate rated capacity or smaller generation facility to HHHI's distribution system, you hereby agree to the following terms and conditions.

1.0 Eligibility

- 1.1 You agree that your generation connection shall be subject to all applicable laws and bound by the terms and conditions of HHHI's Conditions of Service as amended from time-to-time, which have been filed with the Ontario Energy Board and are available on request.

2.0 Technical Requirements

- 2.1 You represent and warrant that you have installed or will install prior to the connection of your generation facility to HHHI's distribution system, an isolation device satisfying Section 84 of the Ontario Electrical Safety Code and agree to allow HHHI's staff access to and operation of this as required for the maintenance and repair of the distribution system.
- 2.2 You agree to perform regular scheduled maintenance to your generation facility as outlined by the manufacturer in order to assure that connection devices, protection systems, and control systems are maintained in good working order and in compliance with all applicable laws.
- 2.3 You agree that during a power outage on HHHI system your generation facility will shut down, unless you have installed special transfer and isolating capabilities on your generation facility. You agree to the automatic disconnection of your generation facility from HHHI's distribution system, as per the generator protective relay settings set out in this Agreement, in the event of a power outage on HHHI's distribution system or any abnormal operation of HHHI's distribution system.
- 2.4 You covenant and agree that the design, installation, maintenance, and operation of your generation facility are conducted in a manner that ensures the safety and security of both the generation facility and HHHI's distribution system.
- 2.5 Due to HHHI's obligation to maintain the safety and reliability of its distribution system, you acknowledge and agree that in the event HHHI determines that your generation facility (i) causes damage to; and/or (ii) is producing adverse effects affecting other distribution system customers or HHHI's assets, you will disconnect your generation facility immediately from the distribution system upon direction from HHHI and correct the problem at your own expense prior to reconnection.

3.0 Liabilities

- 3.1 You and HHHI will indemnify and save each other harmless for all damages and/or adverse effects resulting from either party's negligence or willful misconduct in the connection and operation of your generation facility or HHHI's distribution system.
- 3.2 HHHI and you shall not be liable to each other under any circumstances whatsoever for any loss of profits or revenues, business interruptions losses, loss of contract or loss of goodwill, or for any indirect, consequential, incidental or special damages, including but not limited to punitive or exemplary damages, whether any of the said liability, loss or damages arise in contract, tort or otherwise.

4.0 Compensation and Billing

- 4.1 If you are not an embedded retail generator, you agree that, subject to any applicable law:
 - a. HHHI will not pay you for any excess generation that results in a net delivery to HHHI between meter reads; and
 - b. there will be no carryover of excess generation from one billing period to the next unless you are, at the relevant time, a net metered generator (as defined in section 6.7.1 of the Distribution System Code).
- 4.2 If you are an embedded retail generator selling output from the embedded generation facility to the Independent Electricity System Operator under contract, you agree that HHHI will pay you for generation in accordance with the Retail Settlement Code.
- 4.3 If you are an embedded retail generator delivering and selling output to HHHI, you agree that HHHI will pay you for generation in accordance with the Retail Settlement Code.

5.0 Termination

- 5.1 You understand that you have the right to terminate this agreement at any time, and that by doing so you are required to disconnect your generation facility and notify HHHI of such action.

6.0 Assignment

6.1 You may assign your rights and obligations under this Agreement with the consent of HHHI, which shall not withhold its consent unreasonably. HHHI shall have the right to assign its rights and obligations under this Agreement without your consent.

I understand, accept and agree to comply with and be bound by the above terms and conditions governing the connection of my generation facility to HHHI's distribution system.

Customer Signature: _____ Date: _____

Print name and HHHI account number: _____

I confirm that the following information is true and accurate:

Nameplate rating of Generator: _____kW Total installed generation _____kW

Type: Wind Turbine Photovoltaic (Solar) Hydraulic Turbine Fuel Cell
 Other _____

Inverter Utilized: Yes No

Inverter Certification: C22.2 #107.1 UL 1741 Site Certified by the ESA

For office use: Station _____ Feeder _____ Date Connected _____

Generator Protective Relay Settings

Table 1 B Inverter Based Generation

The following relay settings shall be used for inverters built to the CSA standard:

Source: CSA C22.2 No. 107.1-01 Table 16

System Voltage $V_n = V$ nominal V (Volts)	Frequency F (Hertz)	Maximum number of cycles to disconnect	
		Seconds	Cycle
$V < 0.5 V_n$	60	0.1	6
$0.5 V_n \leq V < 0.88 V_n$	60	2	120
$1.10 V_n \leq V < 1.37 V_n$	60	2	120
$V > 1.37 V_n$	60	0.033	2
V_n	$F < 59.5^*$	0.1	6
V_n	$F > 60.5$	0.1	6

* The UL1741 & IEEE P1547 Standards use $F < \text{rated} \cdot 0.7$ i.e. 59.3 Hz. To update if CSA C22.2 No. 107.1-01 is changed

Table 2 B Non Inverter Based Generation

HHHI's minimum requirements, for other generation are as follows:

System Voltage $V_n = V$ nominal V (Volts)	Frequency F (Hertz)	Maximum clearing time*	
		Seconds	Cycles
$V < 0.5 V_n$	60	0.16	9.6
$0.5 V_n \leq V < 0.88 V_n$	60	2	120
$1.10 V_n \leq V < 1.20 V_n$	60	1	60
$V \geq 1.20 V_n$	60	0.16	9.6
V_n	$F < 59.3$	0.16	9.6
V_n	$F > 60.5$	0.16	9.6

*Clearing time is the time between the start of the abnormal condition and the generation ceasing to energize the HHHI's distribution system

- If you are uncertain about your generation equipment's protective relay settings, please check with your generating equipment supplier.
- Automatic reconnect setting time for your generator is after 5 minutes of normal voltage and frequency on HHHI's distribution system.

HALTON HILLS HYDRO INC.
FORM OF CONNECTION AGREEMENT FOR A SMALL EMBEDDED GENERATION FACILITY OR A MID-SIZED EMBEDDED GENERATION FACILITY

This Connection Agreement is made this ____ day of _____, _____.

BETWEEN

_____, (the "Distributor")

AND

_____, (the "Customer")

(each a "Party" and collectively the "Parties")

RECITALS

WHEREAS the Distributor is the owner of the distribution system serving the service area described in electricity distribution licence number _____ *[insert licence number]* (the "Licence") issued by the Ontario Energy Board (the "Board") (the "Distributor's distribution system").

AND WHEREAS the Customer owns or operates an embedded generation facility that is located in the Distributor's licensed service area (the "Facility").

AND WHEREAS the Customer has connected or wishes to connect its Facility to the Distributor's distribution system and the Distributor has connected or has agreed to connect the Facility to the Distributor's distribution system.

AND WHEREAS the Distributor has previously reviewed and accepted the Customer's application to connect and related materials that were submitted to the Distributor in accordance with the process set out in the Distribution System Code (the "Code") (altogether, the "Application") and the Distributor and the Customer have signed a connection cost agreement (both of which are attached to this Agreement as Schedule A).

AND WHEREAS in accordance with its Licence and the Code, the Distributor has agreed to offer, and the Customer has agreed to accept, distribution service in relation to the Facility.

NOW THEREFORE in consideration of the foregoing, and of the mutual covenants, agreements, terms and conditions herein contained, the Parties, intending to be legally bound, hereby agree as follows:

1. Definitions and Schedules

1.1 Words and phrases contained in this Agreement (whether capitalized or not) that are not defined in this Agreement have the meanings given to them in the *Electricity Act, 1998*, the *Ontario Energy Board Act, 1998*, any regulations made under either of those Acts, or the Code.

1.2 The following schedules form part of this Agreement:

Schedule A – Application and Connection Cost Agreement (recitals)

Schedule B – Single Line Diagram, Connection Point and Location of Facilities (section 2.3)

Schedule C – List of Other Contracts (section 3.4)

Schedule D – Technical and Operating Requirements (section 4.1(d))

Schedule E – Billing and Settlement Procedures (section 5.3)

Schedule F – Contacts for Notice (section 12.1)

Schedule G – Dispute Resolution (section 16.1)

Schedule H – Provisions Applicable if Facility Financed by a Lender (sections 19.3, 20.3 and 21.1)

Where a schedule is to be completed by the Parties, the Parties may not include in that schedule a provision that would be contrary to or inconsistent with the Code or the remainder of this Agreement.

2. Type of Facility and Customer

2.1 The Facility has a name-plate rated capacity of:

[Parties to check the applicable box below]

more than 12 kW and:

(a) up to and including 500 kW, if the Facility is or will be connected to a less than 15 kV line; or

(b) up to and including 1 MW, if the Facility is or will be connected to a 15 kV or greater line

(in which case the Facility is a “Small Embedded Generation Facility”)

10 MW or less and:

(a) more than 500 kW, if the Facility is or will be connected to a less than 15 kV line; or

(b) more than 1 MW, if the Facility is or will be connected to a 15 kV or greater line

(in which case the Facility is a “Mid-sized Embedded Generation Facility”)

2.2 The Facility is or will be connected:

[Parties to check the applicable box(es) below]

- directly to the Distributor's distribution system
- on the load customer side of a connection point to the Distributor's distribution system
 - the load customer is the same as the Customer
 - the load customer is: _____

2.3 Schedule B sets out the following:

- (a) a single line diagram of the Facility;
- (b) a list of the facilities of one Party that are on the property of the other Party; and
- (c) a diagram of the metering installations applicable to the Facility.

2.4 The Customer:

[Parties to check the applicable box(es) below]

- intends to:
 - sell output from the Facility to the Independent Electricity System Operator and has entered into an agreement with the Independent Electricity System Operator for that purpose
 - deliver and sell output from the Facility to the Distributor

(in which case the Customer is an "Embedded Retail Generator")

- does not intend to sell any of the output of the Facility to the Independent Electricity System Operator or the Distributor

3. Incorporation of Code and Application of Conditions of Service and Other Contracts

- 3.1 The Code, as it may be amended from time to time, is hereby incorporated in its entirety by reference into, and forms part of, this Agreement. Unless the context otherwise requires, all references to "this Agreement" include a reference to the Code.
- 3.2 The Distributor hereby agrees to be bound by and at all times to comply with the Code, and the Customer acknowledges and agrees that the Distributor is bound at all times to comply with the Code in addition to complying with the provisions of this Agreement.
- 3.3 In addition to this Agreement, the relationship between the Distributor and the Customer will be governed by the Distributor's Conditions of Service that are in effect at the relevant time. In the event of a conflict or an inconsistency between a provision of this Agreement and a provision of the Distributor's Conditions of Service, the provision of this Agreement shall govern.
- 3.4 The Distributor may require or may have already required the Customer to enter into one or more of the other contracts listed in Schedule C. In the event of a conflict or an inconsistency between a provision of the Code or this Agreement and a provision of such other contract, the provision of the Code or this Agreement shall govern.

4. Facility Standards

4.1 The Customer shall ensure that the Facility:

- (a) meets all applicable requirements of the Electrical Safety Authority (“ESA”);
- (b) conforms to all applicable industry standards including, but not limited to, those of the Canadian Standards Association (“CSA”), the Institute of Electrical and Electronic Engineers, the American National Standards Institute and the International Electrotechnical Commission;
- (c) is installed, constructed, operated and maintained in accordance with this Agreement, the Distributor’s offer to connect, the requirements of the ESA, the connection cost agreement, all applicable reliability standards and good utility practice; and
- (d) meets the technical and operating requirements set out in Schedule D. These requirements shall not exceed any technical or operating requirements set out in the Code unless the Customer agrees.

5. Charges, Settlement and Billing

5.1 The Customer shall pay the Distributor such charges as may be approved by the Board in relation to the connection of, and the provision of distribution service to, the Facility.

5.2 The Customer agrees to the following in relation to settlement for the output of the Facility:

[Parties to check the applicable box below]

- if the Customer is not an Embedded Retail Generator (see section 2.4)

the Distributor will not pay the Customer for any excess generation that results in a net delivery to the Distributor between meter reads and there will be no carryover of excess generation from one billing period to the next unless the Customer is at the relevant time a net metered generator

- if the Customer is an Embedded Retail Generator (see section 2.4)

the Distributor will settle all applicable payments and charges in accordance with the Retail Settlement Code

5.3 Billing and settlement activities will be conducted in accordance with the procedures set out in Schedule E.

6. Representations and Warranties

6.1 The Customer represents and warrants to the Distributor as follows, and acknowledges that the Distributor is relying on such representations and warranties without independent inquiry in entering into this Agreement:

- (a) the Facility is fully and accurately described in the Application;
 - (b) all information in the Application is true and correct;
 - (c) the Facility is in compliance with all applicable technical requirements and laws;
 - (d) the Customer has been given warranty information and operation manuals for the Facility;
 - (e) the Customer has been adequately instructed in the operation and maintenance of the Facility and the Customer has developed and implemented an operation and maintenance plan based on those instructions;
-

- (f) if the Customer is a corporation or other form of business entity, the Customer is duly incorporated, formed or registered (as applicable) under the laws of its jurisdiction of incorporation, formation or registration (as applicable);
- (g) the Customer has all necessary power, authority and capacity to enter into this Agreement and to perform its obligations under this Agreement;
- (h) this Agreement constitutes a legal and binding obligation on the Customer, enforceable against the Customer in accordance with its terms;
- (i) the Customer holds all permits, licences and other authorizations that may be necessary to enable it to own and operate the Facility; and
- (j) any individual signing this Agreement on behalf of the Customer has been duly authorized by the Customer to sign this Agreement and has the full power and authority to bind the Customer.

6.2 The Distributor represents and warrants to the Customer as follows, and acknowledges that the Customer is relying on such representations and warranties without independent inquiry in entering into this Agreement:

- (a) the Distributor is duly incorporated under the laws of Ontario;
- (b) the Distributor has all necessary power, authority and capacity to enter into this Agreement and to perform its obligations under this Agreement;
- (c) this Agreement constitutes a legal and binding obligation on the Distributor, enforceable against the Distributor in accordance with its terms; and
- (d) any individual signing this Agreement on behalf of the Distributor has been duly authorized by the Distributor to sign this Agreement and has the full power and authority to bind the Distributor.

7. Disconnection Device at the Point of Connection

7.1 The Customer shall furnish and install a disconnection switch at the point of connection for the Facility that opens, with a visual break, all ungrounded poles of the connection circuit. The disconnection switch at the point of connection shall be rated for the voltage and fault current requirements of the Facility, and shall meet all applicable CSA standards, ESA requirements, and all other applicable laws. The switch enclosure, if applicable, shall be properly grounded. The disconnection switch at the point of connection shall be accessible at all times, located for ease of access to the Distributor's personnel, and shall be capable of being locked in the open position. The Customer shall follow the Distributor's procedures for switching, clearance, tagging, and locking.

8. Modifications to the Facility

8.1 The Customer shall not modify its connection assets or the Facility except in accordance with this section. Where the modification will not increase the maximum electrical output of the Facility, the Customer shall give the Distributor no less than 15 working days notice prior to the date on which the modification will be completed. Where the modification will increase the maximum electrical output of the Facility, the Customer shall submit a new application for connection to the Distributor. The Distributor shall process that application for connection in accordance with the Code. The Customer shall not commence such modification until that process has been completed.

9. Insurance

9.1 Throughout the term of this Agreement, the Customer shall carry commercial general liability insurance for third party bodily injury, personal injury, and property damage in an amount as follows:

[Parties to check the applicable box below]

- if the Facility is a Small Embedded Generation Facility (see section 2.1)
not less than \$1,000,000 per occurrence and in the annual aggregate
- if the Facility is a Mid-sized Embedded Generation Facility (see section 2.1)
not less than \$2,000,000 per occurrence and in the annual aggregate

Prior to execution of this Agreement, the Customer shall provide the Distributor with a valid certificate of insurance. The Customer shall provide the Distributor with prompt notice of any cancellation of the Customer's insurance by the insurer.

10. Liability and Force Majeure

- 10.1 The liability provisions of section 2.2 of the Code apply to this Agreement and are hereby incorporated by reference into, and form part of, this Agreement.
- 10.2 A Party shall have a duty to mitigate any losses relating to any claim for indemnification from the other Party that may be made in relation to that other Party. Nothing in this section shall require the mitigating Party to mitigate or alleviate the effects of any strike, lockout, restrictive work practice or other labour dispute.
- 10.3 A Party shall give prompt notice to the other Party of any claim with respect to which indemnification is being or may be sought under this Agreement.
- 10.4 The force majeure provisions of section 2.3 of the Code apply to this Agreement and are hereby incorporated by reference into, and form part of, this Agreement.

11. Facility Commissioning and Testing

- 11.1 The Customer shall give the Distributor at least fifteen days advance written notice of the date(s) and time(s) on which the Facility will be commissioned and tested prior to connection. The Customer shall give the Distributor the same notice in relation to the commissioning and testing of any material modification to the Customer's connection assets or Facility that occurs after connection.
- 11.2 The Distributor shall have the right to witness the commissioning and testing activities referred to in section 11.1.

12. Notice

- 12.1 Any notice, demand, consent, request or other communication required or permitted to be given or made under or in relation to this Agreement shall be given or made: by courier or other personal form of delivery; by registered mail; by facsimile; or by electronic mail. Notices shall be addressed to the applicable representative of the Party identified in Schedule F.
 - 12.2 A notice, demand, consent, request or other communication referred to in section 12.1 shall be deemed to have been made as follows:
 - (a) where given or made by courier or other form of personal delivery, on the date of receipt;
 - (b) where given or made by registered mail, on the sixth day following the date of mailing;
 - (c) where given or made by facsimile, on the day and at the time of transmission as indicated on the sender's facsimile transmission report; and
 - (d) where given or made by electronic mail, on the day and at the time when the notice, demand,
-

consent, request or other communication is recorded by the sender's electronic communications system as having been received at the electronic mail destination.

13. Access to Facility

- 13.1 Each Party shall ensure that its facilities are secured at all times.
- 13.2 The Customer shall permit and, if the land on which the Facility is located is not owned by Customer, cause such landowner to permit, the Distributor's employees and agents to enter the property on which the Facility is located at any reasonable time. Such access shall be provided for the purposes of inspecting and/or testing the Facility as and when permitted by this Agreement, the Code or the Distributor's Conditions of Service or as required to ensure the continued safe and satisfactory operation of the Facility, to ensure the accuracy of the Distributor's meters, to establish work protection, or to perform work.
- 13.3 Any inspecting and/or testing referred to in section 13.2 shall not relieve the Customer from its obligation to operate and maintain the Facility and any related equipment owned by the Customer in a safe and satisfactory operating condition and in accordance with this Agreement.
- 13.4 The Distributor shall have the right to witness any testing done by the Customer of the Facility and, to that end, the Customer shall provide the Distributor with at least fifteen working days advance notice of the testing.
- 13.5 Notwithstanding section 10.1, where the Distributor causes damage to the Customer's property as part of this access, the Distributor shall pay to the Customer the Customer's reasonable costs of repairing such property or, if such property cannot be repaired, replacing such property.
- 13.6 Notwithstanding section 10.1, if the Customer has been given access to the Distributor's property, and if the Customer causes damage to the Distributor's property as part of that access, the Customer shall pay to the Distributor the Distributor's reasonable costs of repairing such property or, if such property cannot be repaired, replacing such property.

14. Disconnection of Facility to Permit Maintenance and Repairs

- 14.1 If the Customer requests it, the Distributor will provide the Customer with reasonable notice of any planned equipment outages in the Distributor's distribution system that occur on or after the date of the Customer's request which will impact the Facility or its connection.
 - 14.2 The Distributor will make reasonable efforts to ensure that the outages referred to in section 14.1 will be of minimal duration and cause minimal inconvenience to the Customer.
 - 14.3 In connection with any planned equipment outage, either Party may disconnect or isolate, or require the disconnection or isolation of, its Facility or system (as applicable) from the other Party's Facility or system (as applicable) so that the employees, contractors or agents of the Party may construct, maintain, repair, replace, remove, investigate or inspect its own Facility or system (as applicable) in accordance with the terms of this Agreement and good utility practice.
 - 14.4 Where practical, the Customer shall notify the Distributor prior to temporarily isolating or disconnecting the Facility from the Distributor's distribution system.
-

15. Disconnection of Facility for Other Reasons

- 15.1 The Customer shall discontinue operation of the Facility and the Distributor may isolate or disconnect the Facility from the Distributor's distribution system, upon any of the following:
- (a) termination of this Agreement in accordance with section 19;
 - (b) if the Customer's connection assets or the Facility are modified by the Customer in a manner contrary to section 8.1;
 - (c) during an emergency or where necessary to prevent or minimize the effects of an emergency;
 - (d) in accordance with section 31, 31.1 or 40(5) of the *Electricity Act, 1998*, other applicable law, the Code, the Distributor's Licence or the Distributor's Conditions of Service; or
 - (e) where required to comply with a decision or order of an arbitrator or court made or given under Schedule G.
- 15.2 In the event of disconnection under section 15.1(b), the Facility shall remain isolated or disconnected from the Distributor's distribution system until the connection process referred to in section 8.1 has been completed.
- 15.3 In the event of disconnection under section 15.1(c), the Distributor shall reconnect, or permit the reconnection of, the Facility to the Distributor's distribution system when it is reasonably satisfied that the emergency has ceased and that all other requirements of this Agreement are met.
- 15.4 In the event of disconnection under section 15.1(d) or 15.1(e), the Distributor shall reconnect, or permit the reconnection of, the Facility to the Distributor's distribution system when the Distributor is reasonably satisfied that the reason for the disconnection no longer exists, the Customer agrees to pay all Board-approved reconnection costs charged by the Distributor, and the Distributor is reasonably satisfied of the following, where applicable:
- (a) the Customer has taken all necessary steps to prevent the circumstances that caused the disconnection from recurring and has delivered binding undertakings to the Distributor that such circumstances shall not recur; and
 - (b) any decision or order of a court or arbitrator made or given under Schedule G that requires a Party to take action to ensure that such circumstances shall not recur has been implemented and/or assurances have been given to the satisfaction of the affected Party that such decision or order will be implemented.
- 15.5 Where the Facility has been isolated or disconnected, each Party shall be entitled to decommission and remove its assets associated with the connection. Each Party shall, for that purpose, ensure that the other Party has all necessary access to its site at all reasonable times.
- 15.6 The Customer shall continue to pay for distribution services provided up to the time of isolation or disconnection of its Facility.
- 15.7 The Customer shall pay all reasonable costs including, but not limited to, the costs of removing any of the Distributor's equipment from the Customer's site, that are directly attributable to the isolation or disconnection of the Facility and, where applicable, the subsequent decommissioning of the Facility. The Distributor shall not require the removal of the protection and control wiring on the Customer's site.
- 15.8. While the Facility is isolated or disconnected, the Distributor shall not be required to convey electricity to or from the Facility.

16. Dispute Resolution

16.1 Any dispute between the Customer and the Distributor arising under or in relation to this Agreement will be resolved in accordance with Schedule G. The Parties shall comply with the procedure set out in Schedule G before taking any civil or other proceeding in relation to the dispute, provided that nothing shall prevent a Party from seeking urgent or interlocutory relief from a court of competent jurisdiction in the Province of Ontario in relation to any dispute arising under or in relation to this Agreement.

17. Amendments

17.1. The Parties may not amend this Agreement without leave of the Board except where and to the extent permitted by this Agreement.

17.2. The Parties may by mutual agreement amend this Agreement to reflect changes that may from time to time be made to the Code during the term of this Agreement.

17.3. The Parties may by mutual agreement amend any portion of a schedule that was originally to be completed by the Parties.

17.4. No amendment made under section 17.2 or 17.3 shall be contrary to or inconsistent with the Code or the remainder of this Agreement.

17.5. The Parties shall amend this Agreement in such manner as may be required by the Board.

17.6. Any amendment to this Agreement shall be made in writing and duly executed by both Parties.

18. Waiver

18.1. A waiver of any default, breach or non-compliance under this Agreement is not effective unless in writing and signed by the Party to be bound by the waiver. The waiver by a Party of any default, breach or non-compliance under this Agreement shall not operate as a waiver of that Party's rights under this Agreement in respect of any continuing or subsequent default, breach or non-compliance, whether of the same or any other nature.

19. Term of Agreement and Termination

19.1. This Agreement shall become effective upon execution by the Parties, and shall continue in effect until terminated in accordance with section 19.2 or 19.3.

19.2. The Customer may, if it is not then in default under this Agreement, terminate this Agreement at any time by giving the Distributor thirty days prior written notice setting out the termination date.

19.3. Except as set out in Schedule H, the Distributor may terminate this Agreement upon any material breach of this Agreement by the Customer (a "Default"), if the Customer fails to remedy the Default within the applicable cure period referred to in section 19.4 after receipt of written notice of the Default from the Distributor.

19.4. The Customer shall cure a Default within the applicable cure period specified in the Code or the Distributor's Conditions of Service. If no such cure period is specified in relation to a given Default, the cure period shall be sixty working days.

19.5. Termination of this Agreement for any reason shall not affect:

- (a) the liabilities of either Party that were incurred or arose under this Agreement prior to the time of termination; or
-

- (b) the provisions that expressly apply in relation to disconnection of the Customer's facilities following termination of this Agreement.

19.6 Termination of this Agreement for any reason shall be without prejudice to the right of the terminating Party to pursue all legal and equitable remedies that may be available to it including, but not limited to, injunctive relief.

19.7 The rights and remedies set out in this Agreement are not intended to be exclusive but rather are cumulative and are in addition to any other right or remedy otherwise available to a Party at law or in equity. Nothing in this section 19.7 shall be interpreted as affecting the limitations of liability arising from section 10.1 or the obligation of a Party to comply with section 16 while this Agreement is in force.

19.8 Sections 19.5 to 19.7 shall survive termination of this Agreement.

20. Exchange and Confidentiality of Information

20.1 Confidential information in respect of a Party means (i) information disclosed by that Party to the other Party under this Agreement that is in its nature confidential, proprietary or commercially sensitive and (ii) information derived from the information referred to in (i), but excludes the following:

- (a) information that is in the public domain; or
- (b) information that is, at the time of the disclosure, in the possession of the receiving Party, provided that it was lawfully obtained from a person under no obligation of confidence in relation to the information.

20.2 Subject to section 20.3, each Party shall treat all confidential information disclosed to it by the other Party as confidential and shall not, without the written consent of that other Party:

- (a) disclose that confidential information to any other person; or
- (b) use that confidential information for any purpose other than the purpose for which it was disclosed or another applicable purpose contemplated in this Agreement.

Where a Party, with the written consent of the other Party, discloses confidential information of that other Party to another person, the Party shall take such steps as may be required to ensure that the other person complies with the confidentiality provisions of this Agreement.

20.3 Nothing in section 20.2 shall prevent the disclosure of confidential information:

- (a) where required or permitted under this Agreement, the Code, the Market Rules or the Distributor's Licence;
- (b) where required by law or regulatory requirements;
- (c) where required by order of a government, government agency, regulatory body or regulatory agency having jurisdiction;
- (d) if required in connection with legal proceedings, arbitration or any expert determination relating to the subject matter of this Agreement, or for the purpose of advising a Party in relation thereto;
- (e) as may be required to enable the Distributor to fulfill its obligations to any reliability organization; or
- (f) as may be required during an emergency or to prevent or minimize the effects of an emergency.

20.4 Notwithstanding section 10.1, a Party that breaches section 20.2 shall be liable to the other Party for any and all losses of the other Party arising out of such breach.

20.5 The Parties agree that the exchange of information, including, but not limited to, confidential

information, under this Agreement is necessary for maintaining the reliable operation of the Distributor's distribution system. The Parties further agree that all information, including, but not limited to, confidential information, exchanged between them shall be prepared, given and used in good faith and shall be provided in a timely and cooperative manner.

- 20.6 Each Party shall provide the other with such information as the other may reasonably require to enable it to perform its obligations under this Agreement.
- 20.7 Each Party shall, as soon as practicable, notify the other Party upon becoming aware of a material change or error in any information previously disclosed to the other Party under this Agreement and, in the case of the Customer, in any information contained in its Application. The Party shall provide updated or corrected information as required to ensure that information provided to the other Party is up to date and correct.
-

21. Assignment, Successors and Assigns

- 21.1 Except as set out in Schedule H, the Customer shall not assign its rights or obligations under this Agreement in whole or in part without the prior written consent of the Distributor, which consent shall not be unreasonably withheld or unduly delayed. The Distributor may withhold its consent to any proposed assignment until the proposed assignee assumes, in writing, all of the Customer's obligations contained in this Agreement.
- 21.2 The Distributor shall have the right to assign this Agreement in whole upon written notification to the Customer.
- 21.3 This Agreement shall be binding upon and enure to the benefit of the Parties and their respective successors and permitted assigns.

22. Governing Law

- 22.1. This Agreement shall be governed by the laws of the Province of Ontario and the federal laws of Canada applicable therein.

23. Entire Agreement

- 23.1 Except as expressly provided herein, this Agreement constitutes the entire agreement between the Parties with respect to the subject-matter hereof and supersedes all prior oral or written representations and agreements of any kind whatsoever with respect to the subject-matter hereof.

IN WITNESS WHEREOF, the Parties hereto, intending to be legally bound, have caused this Agreement to be executed by their duly authorized representatives.

Customer Signature

Date

Name (Print)

Title

Distributor Signature

Date

Name (Print)

Title

SCHEDULE A

Application and Connection Cost Agreement (recitals)

See the attached Application and connection cost agreement.

[To be attached by the Parties]

SCHEDULE B

**Single Line Diagram, Connection Point and Location of Facilities
(section 2.3)**

B.1 Single Line Diagram and Connection Point

[To be inserted by the Parties – Following this page]

B.2 List of Facilities on the Property of the Other Party

B.2.1 The following facilities of the Customer are located on the property of the Distributor:

[To be completed by the Parties – List all below]

1. _____
2. _____
3. _____
4. _____
5. _____

B.2.2 The following facilities of the Distributor are located in the property of the Customer:

[To be completed by the Parties – List all below]

1. _____
2. _____
3. _____
4. _____
5. _____

B.3 Metering Installation Diagram

[To be inserted by the Parties – Following this page]

SCHEDULE C

List of Other Contracts (section 3.4)

The following other contracts have been or will be entered into by the Parties:

[To be completed by the Parties – List all below]

1. _____
 2. _____
 3. _____
 4. _____
 5. _____
-

SCHEDULE D

Technical and Operating Requirements (section 4.1(d))

The following technical and operating requirements apply to the Facility:

The technical requirements as specified within Halton Hills Hydro's Guidelines for Applicants Connecting Distributed Generation and as stated within the Connection Impact Assessment (CIA) for the Facility shall apply to this Facility. The contract Facility shall adhere to the requirements at all times unless otherwise agreed upon Halton Hills Hydro.

The following technical and operating requirements apply to the Facility:

D.1 GENERAL TECHNICAL REQUIREMENTS FOR FACILITIES

D.1.1. Subject to Section 6.2.28 and 6.2.29 of the Distribution System Code, the Parties shall comply with the general technical requirements set out in the Distribution System Code, the requirements listed in the Halton Hills Hydro Inc.'s Connection Impact Assessment (HHHI CIA) and the Distributed Generation Technical Interconnection Requirements in effect on Date of CIA.

D.2 FACILITY STANDARDS

D.2.1. In addition to the requirements of section 4 of the Agreement, the Generator shall ensure that the Facility and all equipment therein shall be installed, constructed, operated and maintained in accordance with the manufacturer's recommendations. Maintenance shall be conducted on a regular, planned basis. The Generator shall have a regular, scheduled maintenance plan to ensure that the Generator's connection devices, protection systems and control systems are maintained in good working order and shall provide the Distributor with a copy of such maintenance plan, at any time, upon the Distributor's request.

D.3 REQUIREMENTS FOR OPERATIONS AND MAINTENANCE

D.3.1. Ownership and Controlling Authority

D.3.1.1. A Party may change its designated Controlling Authority set out below at any time during the term of the Agreement, subject to the following conditions:

- a) Either Party shall notify the other in writing of any change in its designated Controlling Authority at least ten (10) working days before implementing a change.
- b) Notification of any changes to the Controlling Authority shall be exchanged between Halton Hills Hydro and Generator as follows:

DISTRIBUTOR	GENERATOR
<ul style="list-style-type: none">• HHHI – Operating Supervisor (see Schedule F, section F.1)• All affected Controlling Authorities	<ul style="list-style-type: none">• Name & Title (see Schedule F, section F.1)• All affected Controlling Authorities

D.3.2. Ownership and Operating Control by Distribution System Substation

- a) The HHI Control Room is the Controlling Authority of the Distributor's Facilities and Equipment listed below except where otherwise indicated. The Generator's Controlling Authority has control over all Generator Equipment except where otherwise indicated.

In the following table Controlling Authority belongs to the Owner, unless otherwise noted as follows: (*D) – Controlling Authority belongs to the Distributor, (*G) – Controlling Authority belongs to the Generator, (*T) – Controlling Authority belongs to the Transmitter.

Error! Reference source not found.			
Owner:	Generator	Distributor	Transmitter
Breakers:			
Switches / Fuses:			
Loops:			
Feeder / Conductors:			
Protection Systems:			
Tele-communications:			
Transformers:			

- D.3.3. Includes a list of any Generator Equipment on the Distributor's property and vice versa, not included in D.3.2 above. The information below is from Schedule B, sections B.2.1.1 & B.2.2.1

Generator Equipment on the Distributor's Property	Distributor's Equipment on Generator's Property

Includes a list of any Generator Equipment on the Transmitter's property and vice versa, not included in D.3.2 above. The information below is from Schedule B, sections B.2.1.2 & B.2.2.2.

Generator Equipment on the Transmitter's Property	Transmitter's Equipment on Generator's Property

D.3.4. **Communication Between the Parties**

- D.3.4.1. Communications shall be addressed to the applicable representative of the party identified in Schedule F (Contacts for Notice) of this agreement.

- D.3.4.2. Upon planning any changes that could affect the reliability of the Distributor's distribution system, the Generator shall promptly submit a written report to the Distributor describing any and all changes in the information that it submitted as registered system planning data in the Connection application form, including, without limitation, changes to Generator Equipment, and associated protective relaying or protective relaying settings, or any other changes of any kind whatsoever that might affect the reliability of the Distributor's distribution system. The portion of this protection that affects the Distributor's distribution system must be designed, and installed in a manner that is acceptable to the Distributor in order for the Generator to remain connected.
- D.3.4.3. All communications between the Parties about day-to-day operating and maintenance matters shall at all times go through the controlling authorities, or those other persons to whom a Controlling Authority has delegated the communication authority.
- D.3.4.4. Each Party shall provide the other with the name of a current 24-hour contact to respond to operating and maintenance matters, which shall be listed in a schedule to the Agreement.
- D.3.4.5. Each Party shall provide the other with all necessary instructions for Emergency responses, including reporting procedures and the names of site Emergency coordinators as and when necessary.
- D.3.4.6. Each Party shall provide the other with all required Work Protection documentation and written notices.
- D.3.5. **Reporting Protocol**
- D.3.5.1. The Distributor shall promptly report to the Generator any changes in the Distributor's Facilities and Equipment that could materially affect the Connection Service provided to the Generator.
- D.3.5.2. The Generator shall promptly report to the Distributor any changes in its - equipment that could materially affect the performance of the Distributor's distribution system.
- D.3.5.3. The Generator shall provide prompt notice to the Distributor in accordance with Sections 14 & 15 of the Main Body of this Agreement before connecting or disconnecting the Generator Equipment from the Distributor's distribution system.
- D.3.5.4. Upon the Distributor's request, the Generator shall promptly report to the Distributor any and all incidents involving the automatic operation of the Generator's protective relaying that could affect Distributor's Facilities and Equipment or Transmitter's Facilities and Equipment and/or potentially result in personal injury (including death).
- D.3.5.5. Upon the Generator's request, the Distributor shall promptly report to the Generator any and all incidents involving the automatic operation of the Distributor's protective relaying that could affect Generator Equipment.
- D.3.6. **Work by the Distributor's Staff on the Generator's Site and Facilities**
- D.3.6.1. When the Distributor's staff, its contractors, or Agents work at the Generator's site, such staff, contractors and Agents shall observe the Generator's safety and environmental requirements.
-

D.3.6.2. Notwithstanding D.3.6.1 above, when the Distributor can demonstrate to the Generator's satisfaction, acting reasonably that the Distributor's safety and environmental practices provide for an equivalent or better level of safety or environmental protection, the Generator shall permit the Distributor to use its safety and environmental practices. As a minimum, all Applicable Laws shall govern such work.

D.3.7. Work by the Generator's Staff on the Distributor's Site

D.3.7.1. When the Generator's staff, its contractors, or Agents work at the Distributor's site, the Distributor's safety and environmental requirements shall be observed by such staff, contractors and Agents.

D.3.7.2. Notwithstanding D.3.7.1 above, when the Generator can demonstrate to the Distributor's satisfaction, that the Generator's safety and environmental practices provide for an equivalent or better level of safety or environmental protection, the Distributor shall permit the Generator to use its safety and environmental practices. As a minimum, all Applicable Laws shall govern such work.

D.3.8. Day to Day Operations & Maintenance

D.3.8.1. Only Qualified persons shall perform operations and maintenance.

D.3.8.2. The Generator shall be responsible for operating and maintaining Generator Equipment in accordance with Good Utility Practice, all Applicable Laws, the Code and the Agreement.

D.3.8.3. The Distributor shall be responsible for operating and maintaining the Distributor's Facilities and Equipment in accordance with Good Utility Practice, all Applicable Laws, the Code and the Agreement.

D.3.9. Normal Operations

HHHI Controlling Authority:	HHHI Control Room
HONI Controlling Authority:	n/a
Station Operating Designation:	Error! Reference source not found.
Generator Business:	Commercial Generator
Generator Contact Information:	Schedule F
Generator Single Line Diagram:	Appendix B-1
Equipment Ownership & Operating Control:	Schedule D.3.2.
Emergency DG Disconnect or Isolator Device:	Schedule D.3.2 and D.3.12.4
Transfer Trips to DG:	n/a
Normal Supply Configuration:	Error! Reference source not found.
Alternate Supply Configuration:	n/a
Failure of Generator Interface protections:	Schedule D.3.9.6.1 and D.7.7
Failure of TT/DGEO tele-protections:	n/a
Failure of Tele-metering:	Schedule D.3.9.8 and D.7.7
Maximum Permissible Active Power:	Error! Reference source not found.

- a) Under normal operating conditions (healthy system voltage & frequency) the Generator is free to connect/disconnect from the Distributor's distribution system (excluding maintenance and repairs) without notifying the Distributor's Controlling Authority. The Distributor always treats the Facility as being Connected. For example, a solar farm may wish to disconnect at night time to reduce no load losses. Wind farms may disconnect when there is no wind.
- b) If at any time the utility supply is lost for more than fifteen (15) minutes, **the Generator must verbally contact the Distributor's Controlling Authority as identified in Schedule F.1 and be granted permission before injecting electricity into the Distributor's Distribution System.**
- c) (If applicable) If for any reason the Generator's normal or approved alternate supply is changed, the Distributor's Controlling Authority will immediately contact the Generator and the Generator shall promptly cease injecting electricity into the Distributor's Distribution System. The Facility may stay connected as a load customer. Once the Distributor's Distribution System is restored, the Distributor's Controlling Authority will contact the Generator to inform them they may reconnect their Facility for generation purposes.

D.3.9.1. **Hold-off Procedures**

- a) A Hold-off is used to restrict the operation of a device to previously agreed limits, except with the Holder's consent.
- b) Hold-offs are most commonly used to block the auto reclosing and the manual re-energization of a line following an automatic trip.
- c) Under no circumstances shall a Hold-off be used in place of a Work Protection.
- d) If remote control is lost to devices under a Hold-off, the Controlling Authority must notify the Holder that the Hold-off is no longer in effect until the integrity of the Hold-off is confirmed.
- e) When a Hold-off is in effect on a line or other apparatus, it shall not be re-energized following an automatic trip until communication is established with the holder and his/her consent is obtained. It is a basic requirement of Hold-off procedures that satisfactory communication be established and maintained between the Controlling Authority and the Holder of the Hold-off.

D.3.9.2. **Switching**

- a) The Generator must comply with the Utility Work Protection Code when performing all switching operations.
 - b) A Party's Controlling Authority shall be responsible for establishing in writing for agreement by the other Party, the appropriate conditions for and the co-ordination of switching on the equipment under its control from time to time throughout the term of the Agreement.
 - c) When the Parties have so agreed in writing, one Party may appoint an employee of the other as its designate for switching-purposes.
-

- d) The Generator shall comply with all switching instructions issued by the Distributor's Controlling Authority to maintain the security and reliability of the Distributor's distribution system. The two Controlling Authorities shall agree to procedures prior to undertaking any switching-operations.

D.3.9.3. Limitations of Distribution System

- a) Due to design or protection limitations in the Distributor's distribution system, or the Transmitter's transmission system or transformer station, the following are the only supply configurations that can be used for the Facility's Connection:

SUPPLY	NORMAL	ALTERNATE
Station:	Error! Reference source not found.	n/a
Feeder:	Error! Reference source not found.	n/a
Breaker:		n/a

Feeder reclosure time: typically 0.7 to 1 second

- b) Feeder configuration limitations: Normal feeder configuration must comply with Distributor's Operating Diagram for Feeder **Error! Reference source not found.**, however other system configurations and the affect on the Generator may be assessed and approved by the Distributor.
- c) Whenever the Distributor needs to make changes to the Distributor's distribution system or the Transmitter to the Transmitter's transmission system or transformer station, from the allowed supply configuration outlined above, the Facility must first be manually disconnected from the Distributor's distribution system. Abnormal system or equipment conditions and maintenance requirements are expected to be the primary reasons for requiring the Facility to be disconnected.

D.3.9.4. Additional Operating Restrictions

Connection of the Generator's Equipment is contingent on the requirements identified in the following documents:

- CIA dated Date of CIA, included as Appendix D-3
- COVER dated , included as Appendix D-4 (**CHANGE TO HHHI's FORM TITLE**)

D.3.9.5. Distributed (Embedded) Generation Interface Protection

- a) The Generator's Interface Protection must comply with the requirements outlined in the Distribution System Code Appendix F: Process and Technical Requirements for Connecting Embedded Generation Facilities. Furthermore, the Generator's Interface Protection must comply with HHHI CIA and Hydro One's "Distributed Generation Technical Interconnection Requirements Interconnections at Voltages 50KV and Below" in effect on Date of CIA for Generators Connecting to the Distributor's distribution system, except for any deviations specifically listed in the HHHI CIA.

- b) The Generator's Interface Protection must cause the Facility to be disconnected before power restoration to the feeder on the Distributor's distribution system takes place (power restoration will typically take place within 0.7 to 1 seconds where automatic re-closure is used).
-

- c) When Transfer Trip (TT) protections and Distributed Generation End Open logic (DGEO) are required to supplement the Generator's interface protection:
 - i) The TT/DGEO schemes must ensure that the Generator is reliably disconnected before the feeder automatically recloses.
 - ii) The TT is required to ensure that the Facility generation will not cause excessive Temporary Overvoltage (TOV) on the Distributor's distribution system. To prevent excessive TOV the Distributor's protection will initiate TT to quickly disconnect the Generator generation (within 100ms) before the Distributor's supply is disconnected. This 100ms time constraint will normally be achieved by an end-to-end TT time $\leq 50\text{ms}$ and the use of a 3-cycle (50ms) device to disconnect the Generator's generation after the TT is received at the Generator's line terminal.

d) Islanding Protection

The Facility is restricted to parallel operation with the Distribution System. At no time shall the Facility supply the Distributor's distribution system load while the Distributor's distribution system load is separated from the Distribution System (i.e. islanding mode operation is not permitted). The Generator Interface Protection (which is defined in D.3.9.5.5 below) includes under-frequency and under-voltage elements. These elements can only be relied upon to quickly disconnect the Facility for an island condition when the maximum aggregate capacity of the Facility is much lower than the minimum distribution load.

e) Fault Protection

The Facility's protection system (the "Generator Interface Protection") shall be capable of automatically isolating the generator from the Distributor's distribution system for the following:

- i) internal faults within the Facility; and/or
 - ii) external faults on the Distributor's distribution system supply feeder(s) as outlined above.
 - iii) Typically fault protection is provided by over-current, unbalanced voltage, impedance or other fault detection elements.
- f) Fault protection selectivity and sensitivity has to be maintained over the range of minimum to maximum fault currents with in-feed from the Facility.
 - g) The Generator will maintain the Generator's Interface Protection fault protection to provide adequate coverage over the complete lengths of the distribution feeder, and to provide clearance times and coordination of the phase and ground protections for the feeder configuration and fault levels, subject to the Distributor's distribution system supply configuration limitations outlined in D.3.9.3 above. The Generator Interface Protection must clear external faults on the supply feeder(s) at least 200ms prior to the re-closure of the Distributor's feeder breaker(s) at the supply station(s).
 - h) The Distributor will maintain the Distributor's protections to provide adequate coverage over the complete lengths of the distribution feeder, and provide adequate clearance times and coordination of the phase
-

and ground protections for the feeder configuration and fault levels, subject to the Distributor's distribution system supply configuration limitations outlined in D.3.9.3 above.

- i) Items D.3.9.5 (g) and D.3.9.5 (h) above will need to be reviewed and revised as required whenever there are material changes to the Distributor's distribution system or the Facility's capacities or equipment characteristics to maintain adequate protection coordination.
- j) Any material increase to the Facility's generation equipment capacities or material change to equipment characteristics must be applied for and follow the process outlined in the Code, similar to what is done for a new installation. Some examples of material increase or change are:
 - i) MW or MVAR capability of the facility
 - ii) Interface transformer size or winding configuration
 - iii) Protection & control of the facility, including breakers, relays, etc.
 - iv) Electrical single line diagram (SLD) of the facility
 - v) Fuel type or turbine type
 - vi) Change in the Connection location

D.3.9.6. **Failure of Generator Protection**

- a) The Generator shall immediately disconnect the Facility from the Distributor's distribution system whenever the capability of the Generator Interface Protection outlined in section D.3.9.5 fails or becomes disabled. This would include failure or inoperability of Generator Interface Protection system or their associated breakers. The Generator shall immediately disconnect the Facility from the Distributor's distribution system whenever there is a continuous failure of all Transfer Trip or DGEO tele-protection channels for more than 5 seconds. When the Generator supplies a redundant communication source (alternate channel), upon receipt of a trouble alarm the Distributor will notify the Generator of the alarm. Upon receipt of a communication failure alarm, the Generator must immediately disconnect.
- b) An alternate means of removing the Facility energy source from the Distributor's distribution system must be available to cover the situation when the associated breaker fails to open for Generator Interface Protection operation. This could include opening of the isolating switch at the PCC (Point of Common Coupling), disabling an inverter, or removing the prime mover and excitation system as appropriate.
- c) **Where the Facility is greater than or equal to 250 kW, an alarm signal shall be generated and transmitted to the Distributor whenever the condition described in D.3.9.6.1 occurs.** Additional requirements as specified in Hydro One's "Distributed Generation Technical Interconnection Requirements Interconnections at Voltages 50KV and Below" document and the CIA also apply.

D.3.9.7. **Provision of Connection Status and Tele-metered Analog Quantities**

- a) The Generator shall maintain real time status telemetry of the Facility Connection to the Distributor's distribution system. The Distributor will use this signal at the HHHI Control Room as well as the Transmitter's Ontario Grid Control Centre (OGCC) so the Controlling Authorities are aware of the Connection status.
- b) The Generator shall provide real time analog telemetry to the Distributor for per phase and net 3-phase amps, per phase volts, per phase and total active power (kW) and reactive power (KVAR). This information is required by the Controlling Authorities of the Distributor's distribution system to maintain operating control and to facilitate the restoration of the Distributor's distribution system.

D.3.9.8. **Failure of Connection Status and Tele-metered Analog Quantities**

- a) The delivery of the real time data shall have unplanned failure rates of four (4) years MTTF (Mean Time To Failure) and repair times of up to 7 days MTTR (Mean Time To Repair) or less as stated in D.7.8. If the failure rates or repair time performance fails to achieve these targets by a significant amount (less than 2 years MTBF (Mean Time Between Failures) or greater than 7 days MTTR), then the Generator may be required to disconnect the Facility until the problems are corrected.
- b) The Distributor reserves the right to decide whether or not the Facility will remain connected to the Distributor's distribution system. If the Distributor decides that the Generator must disconnect the Facility from the Distributor's distribution system, the Distributor will notify the Generator through the appropriate communication protocol outlined in the Agreement. The Facility will remain disconnected from the Distributor's distribution system until the communication system is re-established. If the Distributor decides that the Facility can remain connected to the Distributor's distribution system, the Distributor must advise the Generator through the appropriate communication protocol as set out in this Agreement of the situation, the choices available to Generator and the risks involved. The Generator can choose to remain or separate from the Distributor's distribution system at its own risk.

D.3.10. **Isolation of Equipment**

- a) Upon the request of one Party's Controlling Authority, the other Party's Controlling Authority or its designate shall provide the required timely isolation of equipment as required for Emergency switching or to establish a Supporting Guarantee.
- b) In any situation where the Generator-owned load break switch has been opened and locked by the Distributor, the Generator shall not unlock the switch without the express approval of the Controlling Authority of the Distributor's supply feeder.

D.3.10.1. Isolation of Generator's Facilities and Equipment, Distributor's Facilities and Equipment or Transmitter's Facilities and Equipment

- a) If the Generator requires isolation of its Generator Equipment or Distributor's Facilities and Equipment or Transmitter's Facilities and Equipment, then the Generator's Controlling Authority shall deliver a written notice to the Distributor's Controlling Authority to ask for a Supporting Guarantee. The notice shall set out the Distributor assigned equipment operating designations if applicable. The Generator Equipment
-

designations shall be set out in the notice whenever the Distributor's equipment operating designations have not been assigned.

- b) The Distributor shall provide to the Generator the isolation and reconnection of Generator Equipment at the Generator's request at no cost to the Generator, once per year, during normal business hours. The Generator shall pay the Distributor's actual costs for isolating and reconnecting Generator Equipment if the requested isolation and reconnection is for a time outside of normal business hours or for any requests during normal business hours that is in excess of the one "no cost" request per calendar year.

D.3.10.2. Isolation of the Generator Equipment (for attended Facilities)

- a) If the Distributor requires isolation from Generator Equipment then the Distributor shall request the Generator's Controlling Authority to provide a Supporting Guarantee.
- b) The Supporting Guarantee shall identify the Generator's assigned designations for the operating equipment.

D.3.10.3. Alternative Method of Isolation (for unattended facilities)

- a) When establishing Work Protection on equipment under their control, either Party may include devices controlled by the other Party, rather than obtaining a Supporting Guarantee from the other Party.
Permission must first be obtained from the other Party's Controlling Authority.
 - b) The Generator will provide the Distributor with access to their Facilities and Equipment when required to establish the Work Protection.
 - c) Establishing of any Work Protection shall be in accordance with and in compliance with the Utility Work Protection Code.
 - d) The Generator shall maintain the fused disconnect switch, downstream of the PCC, located between the HHHI metering cabinet and the Generator's intermediate transformer. This switch must be capable of interrupting the load current for maximum net generation conditions.
 - e) In all cases the Generator shall comply with Ontario Electrical Safety Code (OESC). Section 84 (Interconnection of Electric Power Production Sources), under 84-026 (Disconnecting means - General), defines the requirement. Some excerpts from the above mentioned document are as follows:
 - f) Disconnecting means shall:
 - i) Have contact operation verifiable by direct visible means
 - ii) Have provision for being locked in the open position
 - iii) Be capable of being operated at rated load
 - iv) Be readily accessible
 - g) In OESC Bulletin 84-1-1 the requirements are as follows: an isolating device shall be installed in a location satisfactory to the supply authority and the inspection department and shall be:
-

- i) Have contact operation verifiable by direct visible means
- ii) A three phase load interrupter device
- iii) Lockable
- iv) Accessible to the supply authority
- v) The isolating device shall have a visual break when installed on system operating at more than 750 volts.

D.3.11. Planned Outages

D.3.11.1. **The Generator shall schedule all planned work with the Distributor's Controlling Authority to co-ordinate Planned Outages that directly affect Distributor's Facilities and Equipment** or Transmitter's Facilities and Equipment.

D.3.11.2. At least ten (10) working days in advance of planned work, the Generator's Controlling Authority shall provide written requests to the Distributor's appropriate contact identified in Schedule F of this Agreement if the planned work involves:

- a) Any disconnection from the Distributor's distribution system, e.g. Disconnection from a feeder breaker owned by the Distributor or by the Transmitter or by the Generator; or
- b) Load changes, transfers or switching operations that directly affect Distributor's Facilities and Equipment or Transmitter's Facilities and Equipment.

D.3.11.3. The Distributor's Controlling Authority shall notify the Generator's Controlling Authority at least two (2) working days in advance of any planned work that directly affects Generator Equipment, by contacting the Generator's appropriate contact identified in Schedule F.

D.3.11.4. Either Party's Controlling Authority shall provide notice of a change in the date and time of pre-planned work, at least two (2) working days in advance of the planned date.

D.3.11.5. If the change can be reasonably accommodated, both Parties shall establish a new date. If the Parties cannot agree, the Distributor will have the right to set the date of the Planned Outage upon providing the Generator with not less than two (2) working days prior notice.

D.3.12. Emergency Operations

D.3.12.1. Forced Outage

- a) When a Forced Outage by one Party adversely affects the other's equipment or facilities, the first Party's Controlling Authority shall make best efforts to notify to the Controlling Authority of the second Party.
- b) Each Party's Controlling Authority shall have sole authority to identify the need for and initiate a Forced Outage on equipment under its control.

D.3.12.2. Emergency Operations

The Distributor may be required from time to time to interrupt the provision of Distribution Services to the Generator during an Emergency to prevent imminent injury to persons, to protect the stability, reliability, and integrity of the Distributor's Facilities and Equipment or Transmitter's Facilities and Equipment, or to maintain its equipment availability. During an Emergency, either Party may take whatever immediate action it deems necessary and is Qualified to perform to safeguard public safety, life, and property without first notifying the other Party.

D.3.12.3. **Conditions of Restoration**

- a) When a Distributor's distribution feeder has been automatically removed from service then:
 - i) Attempts to energize the feeder can be made after consultation with the Emergency Response and/or Operations Department and is at the discretion of the Distributor's Controlling Authority
 - ii) Should restoration attempts by the Distributor to the distribution system fail to re-establish stable voltages within 15 minutes, automatic reconnection of the Facility interconnection system shall be disabled and all future reconnection requests after 15 minutes shall be authorized by the Distributor's Controlling Authority.

b) Reconnect as a Load

Following an automatic feeder removal, the Facility may automatically **reconnect as load only** once the distribution system voltages are stable within normal limits for continuous period of 15 – 30 seconds in order to restore power to their Station Service, DGIT and other critical loads.

c) Resynchronize Generators and Provide Energy to System

- i) Once the Facility has successfully reconnected to the distribution system as a load following an automatic feeder removal, the Facility may resynchronize generation and provide energy to the distribution system once voltage is stabilized to within 6% of nominal, frequency is between 59.5Hz and 60.5Hz, and 5 minutes has passed since the initial event.
- ii) If synchronization is to occur after 15 minutes from the start of the automatic feeder removal, all requests must be authorized by the controlling authority to allow for **manual** resynchronization.

d) Emergency Switching

The Distributor's personnel may request and obtain the permission of the Generator's Controlling Authority to act as the Issuing and Establishing Authority under the Utility Work Protection Code with respect to the ability to operate the Generator-owned fused disconnect switch during emergencies. The Distributor shall have the capability to unlock, operate and lock the fused switch using the Distributor's lock in a double-lock arrangement (as shown in Appendix D-2). The Distributor will notify the Generator as soon as practical following an emergency operation giving conditions and related details.

D.4 METERING REQUIREMENTS

D.4.1. Embedded Market Participant Generators

If the Generator has elected to be a Market Participant or has been assessed by the IESO to have impacts on system limits, the Generator will be responsible for the ownership, installation and maintenance of the meter and to contract the services of a registered MSP. The metering standards are as prescribed in the Market Rules.

D.4.2. Non – Market Participant Generators

Metering requirements for embedded non – Market Participant generators are defined in the current "Halton Hills Hydro Inc. Metering Specifications" as found on www.HHHydro.com. These specifications may be amended or updated from time to time based upon new rules or regulations announced by the Minister of Energy, the Ontario Energy Board, or other applicable regulatory bodies.

D.5 COMPLIANCE, INSPECTION, TESTING AND MONITORING

- D.5.1. The Generator shall inspect, test and monitor its Generator Equipment connected to the Distributor's distribution system to ensure and maintain compliance with all Applicable Laws, the Conditions of Service, the Code and the Agreement.
- D.5.2. When requested by the Distributor, the Generator shall produce test certificates certifying that its Generator Equipment have passed the relevant tests and comply with all Applicable Laws before Connection.
- D.5.3. The Generator shall provide the Distributor with the Generator's proposed Connection commissioning program and test procedures. Prior to Connection, the Generator will complete and submit a **Confirmation Of Verification Evidence Report (COVER)** as per Instructions for Completing Steps 4 and 5 of that form.
- D.5.4. Within thirty (30) working days of receiving the above documentation or as required by the Code, the Distributor shall notify the Generator that it:
- a) agrees with the proposed Connection commissioning program and test procedures; or
 - b) requires changes in the interest of safety or maintaining the reliability of the Distributor's distribution system, and that such request for changes shall be sent to the Generator promptly.
- D.5.5. The Distributor may inspect Generator Equipment and/or request to witness or participate in any commissioning tests related to new or replacement equipment that could reasonably be expected to affect the performance of the Distributor's distribution system. The Generator shall pay the Distributor all actual costs associated with witnessing such tests. For those tests that require the Distributor's participation or witnessing, the Generator shall provide the Distributor with no less than fifteen (15) working days prior written notice. Note: All tests must be coordinated and approved ahead of time through the normal outage and work management system planning processes.
- D.5.6. The Generator must submit proof that their Equipment has been inspected and approved by ESA prior to Connection or start of commissioning (authorization to connect). Any future changes to Generator Equipment must also be approved by ESA (alternatively the Generator may provide proof of an exemption from ESA to the Distributor).
- D.5.7. At least three (3) weeks prior to Connection, the Generator shall have provided the Distributor with a Commissioning Report complete with the Distributor accepted Generator Interface Protection settings that summarize the results of the commissioning program and tests completed in accordance with the final plan as determined by Item D.5.4 above.
- D.5.8. Immediately following Connection, the Generator will complete Final Potential and On-load Checks and will complete and submit **Confirmation Of Verification Evidence Report (COVER)** as per Instructions for Completing Step 6 of that form.

D.6 RE-VERIFICATION OF PROTECTION AND CONTROL SYSTEMS

- D.6.1. The Generator shall re-verify its station protections and control systems that can impact on the Distributor's distribution system. Requirements will be equivalent to what the Distributor would require for re-verification of its own facilities that have similar potential impact to the Distributor's distribution system, normally every four (4) years.
- D.6.2. Protection and control systems re-verification tests shall cover the tests conducted during commissioning listed in the **COVER** document. ~~For more information please reference the latest Hydro One Distributed Generation Technical Interconnection Requirements Document DT-10-015.~~
- D.6.3. Within three (3) months of Connection, the Generator shall provide the Distributor with the Generator's proposed protection and control re-verification program (including test procedures and schedules).
- D.6.4. Within thirty (30) working days of receiving the above documentation or as required by the Code, the Distributor shall notify the Generator that it:
- a) agrees with the proposed re-verification program and test procedures; or
 - b) requires changes in the interest of safety or maintaining the reliability of the Distributor's distribution system, and that such request for changes shall be sent to the Generator Promptly.
- D.6.5. For those tests that require the Distributor's participation or witnessing, the Generator shall provide the Distributor with no less than fifteen (15) working days notice. Note: All tests must be coordinated and approved ahead of time through the normal outage and work management system planning processes.
- D.6.6. The Generator will complete the re-verification in accordance with D.6.3 above and submit complete documentation of the test results to the Distributor within one month of the completed tests.

D.7 TELEMETRY, MONITORING, AND TELEPROTECTIONS

The Distributor shall advise Generators of the performance and details of required tele-metering facilities that serve them. Some requirements depend on the size and specific location of the Connection to the Distributor's distribution system. The Distributor shall determine the requirements for telemetry.

D.7.1. Teleprotection Medium

The communication medium used will be **n/a**

D.7.2. Types of Teleprotection Channels

- a) Number of Blocking Channels **n/a**
- b) Number of Transfer Trip Channels **n/a**
- c) Number of Generation/Load Rejection Trip Channels **n/a**
- d) Number of Direct/Remote Trip Channels **n/a**
- e) Number of DGEO Channels **n/a**

The Teleprotection channels shall be monitored in order to assess equipment and channel readiness.

D.7.3. **Ownership of Teleprotection Terminal Equipment**

The terminal equipment located at a given site are owned by the Generator. The communication medium is considered to be owned by Generator. The terminal equipment located at a transformer station are owned by the Distributor or by the Transmitter.

D.7.4. **Responsibility for Work and Costs Associated with Breakdown and Routine Maintenance**

- a) If maintenance is required on the terminal equipment located at the Generator's site, the Generator will bear all incurred costs. If maintenance is required on terminal equipment located at sites owned by the Distributor or Transmitter, the Distributor or Transmitter will bear all incurred costs.
- b) If maintenance or repair is required to the communication circuits, the Generator will incur all associated costs. These costs will include charges by Communication Service Provider and the Distributor if its personnel are required to participate in any of the related activities.

D.7.5. **Re-verification Schedule**

Routine Maintenance on protection communication equipment and the protection communication channels must be performed every two (2) years providing the equipment has self-diagnostic checking mechanisms. Otherwise monthly verifications will be required.

D.7.6. **Inventory of Communication Equipment**

The provision of spare communication equipment is the Generator's responsibility and will be located at its site.

D.7.7. **Failure of Communication Equipment**

- a) If a communication failure affects either the transfer trip channels or the Distributed Generation End Open blocking channels, the action identified in section D.3.9.6.1 will immediately be applied.
- b) If the monitoring or telemetry to the Generators Connection Status, Real Power Output, Reactive Power or Voltage is lost, the action identified in D.3.9.8 will immediately be applied.

D.7.8. **Mean Time for Repairs**

- a) Upon loss of Teleprotections the Generator is required to immediately report the failure cause and estimated repair time to the Controlling Authority. Mean Time for Repair (MTFR) starts from the time when communications was lost and not from when it was discovered. The MTFR is up to 7 days as per D.3.9.8 or less as stated below.
- b) A Mean Time for Repair of up to 24 hours is required if any of the following are applicable;
 - i) DG involved in a Special Protection System (SPS): **n/a**
 - ii) DG involved in Automated Dispatch: **n/a**

D.7.9. **Reporting Requirements for Generators.**

- a) The Generator shall keep a written or electronic log. This log will record the date and time, along with a description of the incident. The incidents recorded, must include, but are not limited to those in the table below. The Generator must make the log, or a copy of the log, available for the Distributor's review upon request, within five (5) working days of that request.
 - b) The Generator will provide reports to the Distributor either on a requested basis, or for specific types on incidents that require reports as per the table within five (5) working days of the incident.
-

- c) The report must include, but is not limited to:
- i) Facility and/or Generator Name and Account Number
 - ii) Supply Feeder
 - iii) Date and time of incident
 - iv) General description of the incident, including cause, if known
 - v) Did the Facility equipment trip correctly
 - vi) Voltage (if available)
 - vii) Frequency (if available)
 - viii) Amps
 - ix) Active Power (kW or MW)
 - x) Reactive Power (kVAR or MVAR)
 - xi) Any available oscillography or digital fault records (DFR) related to the above
 - xii) Generator connection status (individual units)
 - xiii) Transfer Trip signal status
 - xiv) Distributed Generation End Open signal status
 - xv) Which relays operated (targets & description). Any available sequence of events records (SER) related to the above
 - xvi) Corrective actions taken
- d) These are the incident types to be recorded:

Note: the Distributor may modify the incidents to be logged or recorded in the table below, based on those relevant to the Distributor's distribution system specific to this Connection.

Incident	Logged	Report Required	Real Time Communication
Protection System Malfunction or Failure at the Facility (see D.3.9.6)	Yes	As requested	Day of
Trip from the Facility's Relay Operation	Yes	As requested	Within Hour
Electrical failure / incident at the Facility	Yes	As requested	As requested
Mechanical failure / incident at the Facility	Yes	As requested	As requested
Trip from Feeder incident	Yes	As requested	Within Hour

D.8 ACTIVE AND REACTIVE POWER DELIVERIES

- D.8.1. Maximum Permissible Amount for Delivery to the Distributor's distribution system (kW): **Error! Reference source not found.**
- D.8.2. The Generator shall operate the Facility at a constant Power Factor at all times. The Power Factor as specified in the Connection Impact Assessment for the Facility dated Date of CIA (the "CIA") refers to the Power Factor of the contribution of the Facility to the Distributor's distribution system at the PCC at the time the HHHI CIA was performed. As the Distributor's distribution system conditions change from time to time, the Distributor shall have the right, in its sole discretion, to revise the specified Power Factor for the Facility from time to time on not less than 30 days prior written notice to the Generator.
- D.8.3. Power Factor: between 0.9 lagging and 0.95 leading at the Generation Facility's terminals

D.9 GENERATOR EQUIPMENT TERMS

- D.9.1. The Generator shall take reasonable steps to ensure that the operation or failure of any Generator Equipment does not cause a Distribution System outage or disturbance.
- D.9.2. Any Generator condition that adversely affects the Distribution System shall be corrected immediately by the Generator at the Generator's cost.
- D.9.3. Where directed by the Distributor, the Generator shall take corrective or preventative action on the Generator's electric system where there is a direct hazard to the public or the Generator is causing or could cause adverse effects to the reliability of the Distributor's distribution system. If the situation is not corrected, the Distributor may disconnect the Generator in accordance with its disconnection policy in its Conditions of Service.
- D.9.4. Despite Section 2.2.1 of the Code, if damage to the Distribution System or increased operating costs result from the connection of the Facility, the Generator shall reimburse the Distributor for these costs.
- D.9.5. The Distributor may require that Generator Equipment that was connected, operated or ordered before May 1, 2002 be brought into compliance with the technical requirements of the Distribution System Code within a period of time acceptable to the Distributor where it has been identified that:
- a) there is a material deterioration of Distributor's distribution system reliability resulting from the performance of the Generator Equipment; or
 - b) there are material negative impacts on an existing or a new Generator's power quality resulting from the performance of the Generator Equipment; or
 - c) there is a material increase in capacity or load at the site where the Generator Equipment is located.
-

APPENDIX D-1
Definitions



In accordance with Section 1.1 of the Agreement words and phrases command in this Agreement (whether capitalized or not) that are not defined in this Agreement have the meanings given to them in the Electricity Act, 1998, the Ontario Energy Board Act, 1998 any regulations made under either of those Acts, or the Code. Throughout this Schedule "D", unless there is something in the subject matter or context inconsistent therewith, the following words shall have the following meanings:

"A" means Ampere, unit of electrical current.

"Agent" means a qualified person duly authorized by a Generator to perform specific limited operations for the Controlling Authority.

"Applicable Laws", means any and all applicable laws, including environmental laws, statutes, codes, licensing requirements, treaties, directives, rules, regulations, protocols, policies, by-laws, orders, injunctions, rulings, awards, judgments or decrees or any legal requirement or decision or agreement with or by any government or government department, commission, board, court authority or agency.

"Business Day" means a day other than a Saturday, a Sunday, a statutory holiday in Ontario or any other day on which the principal chartered banks located in the City of Toronto, are not open for business during normal banking hours.

"Connect" means to form a physical link to or through the Distributor's distribution facilities.

"Controlling Authority" means a person or officer responsible for performing, directing, or authorizing changes in the conditions or physical position of specific apparatus or devices.

"COVER" stands for the Distributor's "Confirmation of Verification Evidence Report".

"CSA" means Canadian Standards Association.

"Generator Equipment" means all electrical and mechanical equipment used by the Generator and does not include any Distributor's Facilities and Equipment or Transmitter's Facilities and Equipment.

"Defined Point of Sale" shall be the point on the boundary of the IESO-controlled grid at which settlement transactions are deemed to take place.

"De-energized" is a state in which the stored potential energy of an Isolated piece of equipment has been discharged. In an electrical apparatus, electrical energy is typically discharged through a Connection to an effective ground potential.

"Demarcation Point" has the same meaning as "ownership demarcation point" in the Distribution System Code.

"Distributed Generation End Open" or "DGEO" means a real time signal that is continuously sent from the Generator to the Distributor. It establishes the connection status of the generation equipment. The signal is derived from all breakers/circuit switchers at the interface between the Facility and the PCC necessary to establish DG connectivity. DGEO is required at the Distributor Connection location to block closing when the Facility is connected. DGEO may also be required to be sent as real-time-operating data to the OGCC, so the Controlling Authorities of the Distributor's distribution system are aware of the Connection status.

"Distributor's Facilities and Equipment" means Halton Hills Hydro Inc.'s meters, wires, poles, cables, transformers, any other structures, equipment, all other appliances and equipment or other things used for Distributing electricity.

"ESA" means the Electrical Safety Authority.

"Establishing Authority" means a person or officer responsible for preparing, checking and establishing the conditions for a Work Permit or Supporting Guarantee.

"Forced Outage" means the automatic or manual limitation of service by a party's Controlling Authority, owing to de-rating or limitation of equipment, or the unavailability of

equipment as a result of actual or potential failure of that equipment or equipment related to it.

"Good Utility Practice" means any of the practices, methods and acts engaged in or approved by significant portion of the electric utility in North America during the relevant time period, or any of the practices, methods and acts which, in the exercise of reasonable judgment in light of the facts known at the time the decision was made could have been expected to accomplish the desired result at a reasonable cost consistent with good practices, reliability, safety and expedition. Good Utility Practice is not intended to be limited to the optimum practice, method or act to the exclusion of all others, but rather to be acceptable practices, methods, or acts generally accepted in North America.

"Hold off" is used to restrict the operation of a device to previously agreed limits, except with the Holder's consent. Hold-off is most commonly used to block the auto reclosing and the manual re-energization of a line following an automatic trip.

"Holder" is the person who has accepted the Work Permit or Supporting Guarantee and therefore has attained working and/or testing rights for the work group. The Holder is assigned responsibilities for ensuring that everyone in the work group is protected from the viewpoint of the Code.

"IESO" means the Independent Electricity System Operator.

"Isolated" means the state in which a piece of equipment has been disconnected from any source of dynamic energy. Typically, apparatus is isolated by means of devices such as valves or electrical switches.

"kVA" Kilovolt-ampere, apparent power (1000 volt-amperes).

"kVARh" Kilovar-hour, (1000 volt-ampere reactive expended in one hour);

"kW" Kilowatt, practical unit of active power (1000 watts).

"kWh" Kilowatt-hour, practical unit of electric energy expended in one hour (1000 watt per hour with respect to time).

"Licence" means a licence issued by the OEB under Part V of the Ontario Energy Board Act.

"Meter Service Provider" or "MSP" means a person that provides, installs, commissions, registers, maintains, repairs, replaces, inspects and tests Metering Installations;.

"OEB" means the Ontario Energy Board.

"Planned Outage" means an outage that results when a component is deliberately taken out of service at a pre-selected time, usually for the purpose of construction, preventive maintenance or repair.

"Point of Common Coupling" or "PCC" has the same meaning as "Point of Supply" in the Distribution System Code and means the point where the Generator's Facilities are to Connect to HHHI's distribution system.

"Power Factor" means the ratio of active to apparent power.

"Promptly" means performed in an expeditious manner and without undue delay, using due diligence, and with the intent of completing a required act or task as quickly as practicable.

"Qualified" means assessed by a party as satisfactory in personal competency, familiarity with and knowledge of all applicable rules, regulations, guidelines, policies, codes, procedures, apparatus and equipment, and dangers of work and operation.

"Rate Order" means an order of the OEB that is in force at the relevant time which, among other things, regulates distribution and distribution rates to be changed by a licensee.

"SCADA" means System Control and Data Acquisition, used to monitor and control the Distributor's distribution system.

"Settlement Hour" means a period of one hour which corresponds to a particular dispatch hour for which metering data determined in accordance with Market Rules and physical market prices for services calculated pursuant to

Market Rules that are to be used to calculate the settlement debits and credits of Market Participants.

“Supporting Guarantee” means a guarantee issued in support of a Work Protection guaranteeing isolation/de-energizing at switches, or other devices, under the Operating Control of the issuer.

“Synchronize” means the process of connecting two previously separated alternating current apparatuses or systems after matching frequency, voltage, phase angles, etc... (e.g., paralleling a generator to the electric system.)

“Taxes” means all property, municipal, sales, use, value added, goods and services, harmonized and any other non-recoverable taxes and other similar charges (other than taxes imposed upon income, payroll or capital).

“Temporary overvoltage” or **“TOV”** means the power-frequency voltage, on a sound phase, at a selected location, during a line-to-ground fault affecting one or more phase.

“Transfer Trip” or **“TT”** means a protection trip signal that is sent from the Distributor source to the Distributed (Embedded) Generation(s) when the Distributor supply to the feeder is interrupted. Transfer Trip is intended to rapidly disconnect the Distributed Generation(s) for the purpose of

minimizing fault duration, preventing island mode operation and to ensure the DG will be disconnected before The Distributor supply is restored.

“Transmitter’s Facilities and Equipment” means Hydro One Network Inc.’s meters, wires, poles, cables, transformers, any other structures, equipment, all other appliances and equipment or other things used for Distributing electricity.

“Under Frequency Load Shedding” means automatic “Load Shedding” by a protective relay, when frequency declines to preset levels on a time curve.

“V” means volt, a measure of electrical voltage.

“VT” means Voltage transformer, instrument transformer that is designed for the measurement of voltage.

“Wholesale Metering” means metering that complies with Chapter 6 of the Market Rules.

“Work Protection” means the provision of a safe environment for work. A guarantee that an Isolated, or Isolated and De-energized condition has been established for work and will continue to exist, except for approved tests; and

“Wye” means the electrical configuration that supports a system neutral.

SCHEDULE E

Billing and Settlement Procedures (section 5.3)

The following provisions apply in relation to billing and settlement in relation to the Facility:

This policy applies to billing and settlement for customers who are enrolled in the Independent System Electricity Operator's (IESO) Feed in Tariff (FIT) program and who are generating into HHH's distribution system. The purpose of this policy is to describe the methodology HHH shall follow in respect to billing and settlement of FIT accounts and the options available to customers for settlement and dispute resolutions.

Halton Hills Hydro Inc. shall endeavor to comply with all relevant governmental codes and policies including but not limited to our Conditions of Service, the Retail Settlement Code, Measurement Canada policies

Payment Schedule & Price:

All payments made to FIT accounts shall be processed monthly following a successful month end meter reading. Payment in the form of a Cheque will be mailed to the person named on HHH's FIT account.

General settlement inquiries shall be directed to HHH's billing department at 519-853-3700.

The first settlement of contract price may take approximately 60 days following the end of the first month the customer's generation is connected. Prior to the first and subsequent payments being made, HHH will confirm that the Independent Electricity System Operator has issued the customer a complete and final contract stating the contract price and contract duration.

Following the first contract payment, monthly payments of contract price will be issued approximately 15 to 30 days following the end of the month for which the payment is intended (ie: Payment for March will be processed and mailed in mid to late April).

HHH will pay the contract price to the applicant for the period of the contract. Additional or increased payments may be made to the applicant:

- (i) Where price escalation applies, HHH will increase the payment amount in accordance with escalation schedule as determined by the Independent Electricity System Operator;
- (ii) Where on peak performance incentives apply, HHH will credit the customer additional payment amounts as determined applicable by the IESO in their FIT Contract. The On peak performance incentive only applies to generated power delivered to HHH's distribution system during On Peak hours. Off peak hours will receive the standard payment amount as prescribed by the IESO FIT Contract.
- (iii) Where Aboriginal or Community incentives apply, HHH will credit the customer additional payment amounts relating to the applicable incentives as prescribed by the IESO FIT Contract and Section 9 – "Aboriginal and Community Projects" of the FIT Rules.

In respect of the Independent Electricity System Operator, where the customer's generation facility is an IESO Market Participant, section 8.1 of the FIT rules pertaining to settlement shall apply. Where the customer's generation facility is not an IESO Market Participant, sections 8.2 of the FIT rules pertaining to settlement shall apply. If the contract generation facility is an Incremental Project, section 8.3 of the FIT rules shall apply. The following provides more details and is directly from the

HALTON HILLS HYDRO INC.

SMALL OR MID-SIZED GENERATION FACILITY CONNECTION AGREEMENT (Nov 2016)

Page 37 of 43

IESO FIT rules:

Settlement for IESO Market Participants (IESO FIT Rules 1.3.2, Oct. 29, 2010)

- (a) In the case of a Facility that:
- (i) Is directly connected to the IESO-Controlled Grid;
 - (ii) is a Behind-the-Meter Facility and has one or more Registered Facilities connected between it and the IESO-Controlled Grid; or
 - (iii) is otherwise a Registered Facility,

the payments to the Supplier under the FIT Contract will be adjusted by subtracting the greater of the Hourly Ontario Energy Price and zero in respect of all Hourly Delivered Electricity to account for either payments made in accordance with the IESO Market Rules or benefits conferred on the Host Facility, as applicable.

- (b) The IESO will pay the Supplier or the Supplier will pay the IESO, as applicable, any amounts owing under the FIT Contract by direct settlement.

Settlement for Non-IESO Market Participants (IESO FIT Rules 1.3.2, Oct. 29, 2010)

(a) In the case of a Facility that is not a Registered Facility and is connected to either a Distribution System or to a Host Facility that is also not a Registered Facility, the IESO will pay the Supplier any amounts owing under the FIT Contract through settlement between the Supplier and the applicable LDC on a periodic basis in accordance with the applicable LDC's monthly, quarterly or other periodic billing cycle.

(b) In the case of a Facility with a Contract Capacity greater than 5 MW, that is not a Registered Facility or a Behind-the-Meter Facility, the payments to the Supplier under the FIT Contract will be adjusted by subtracting the absolute value of the Hourly Ontario Energy Price for all hours where the Hourly Ontario Energy Price is less than zero, in respect all Hourly Delivered Electricity.

(c) For a Facility that is not a Registered Facility and is connected directly to a Host Facility on a Distribution System that is also not a Registered Facility, the Supplier must maintain a settlement account with the applicable LDC in accordance with the Retail Settlement Code.

(d) Where a Facility that is not a Registered Facility is connected to a Host Facility on a Distribution System and such Host Facility is an Embedded Retail Generator, Contract Payments for any hour will be reduced by the Hourly Delivered Electricity multiplied by the price at which energy sales from such Embedded Retail Generator are settled, in accordance with Section 3.2 of the Retail Settlement Code, unless such Embedded Retail Generator's settlement has already been adjusted to account for the Facility's Hourly Delivered Electricity.

Incremental Projects and Planned Generating Facilities (IESO FIT Rules 1.3.2, Oct. 29, 2010)

Where a Project is a Planned Generating Facility with respect to one or more Incremental Projects, the Hourly Delivered Electricity for such Planned Generating Facility will be adjusted by deducting the amount of Hourly Delivered Electricity attributed to the Incremental Project(s) in accordance with the applicable Incremental Project Ratio(s).

Alternate Settlement Arrangements (IESO FIT Rules 1.3.2, Oct. 29, 2010)

The IESO reserves the right at its sole discretion to make alternate settlement arrangements in respect of the entire FIT Program or in respect of one or more Projects or LDCs at any time and

from time to time. Notwithstanding other parties being involved in the settlement process, the IESO shall remain liable to the Supplier for Contract Payments.

Contract payments will cease to be made by HHH to the customer once the end of the contract is reached. If the customer enrolls in another governmental program or HHH and the customer agree to a contract price and contract length, HHH will continue making payments in accordance with the new program and price. A new Connection Agreement will be required. If the customer makes any material change to their facility, the customer may need to disconnect their generation facility following termination of the FIT contract and submit a new application for connection to HHH.

Disputes & Resolution:

All meter reading and/ or payment disputes will be directed to the Customer Care and Billing Supervisor. Halton Hills Hydro Inc. will work with the customer to address and resolve the dispute in a timely and effective manner.

Where a meter reading is being disputed, HHH may elect to perform a manual read of the meter to help verify if the reading be disputed seems accurate or not. If the customer still believes the meter reading is incorrect, the meter may be removed and sent to an accredited meter laboratory to be checked. HHH will notify the customer making the dispute of the laboratories findings. Following the outcome of the laboratories findings, HHH shall take appropriate action as determined by the Customer Care and Billing Supervisor.

Where a resolution cannot be reached, the Customer Care and Billing Supervisor may elect to escalate the dispute to HHH's senior management.

The customer is encouraged to keep a written record of any telephone conversations they may have with HHH staff concerning their dispute. The customer is also encouraged to make their dispute in writing, directed to the attention of the Customer Care and Billing Supervisor.

Release of Account Information:

The customer may request account details of their account. Such requests must come directly from the customer and must be in writing. Where an agent of the customer requests account details, the agent must produce a letter from the customer directing HHH to what information may be release to the agent. Halton Hills Hydro Inc. employs strict policies about releasing account information. No account information shall be provided by HHH to anyone without the customer's direct written consent.

The customer and/ or their agent should allow for approximately ten (10) business days for HHH to produce the requested information. In some instances, a service charge may apply.

Withholding of Contract Payment:

Halton Hills Hydro Inc. reserves the right to withhold contract payments:

- If the customer's generation facility is in contravention of the Connection Agreement, Independant Electricity System Operator FIT program rules, or Ontario Energy Board Distribution System Code;
- Where the contract facilities output is increased by the customer above and beyond that stated on the Connection Agreement and/ or Independant Electricity System Operator FIT contract;
- If the Independant Electricity System Operator directs HHH to do so;
- Where the customer is disputing a meter reading relating to the billing period for which the payment is meant;
- Where the customer's generation facility presents a potential hazards to the public and the customer has not remedied the potential hazard within the prescribed timeframe as directed

by HHH, the Electrical Safety Authority, the Independent Electricity System Operator, or other applicable agency.
Where Halton Hills Hydro Inc. exercises its right to withhold contract payment, the customer shall be notified by telephone and letter by registered mail.

SCHEDULE F

Contacts for Notice (section 12.1)

[To be completed by the Parties – different contacts may be listed for different purposes]

Contacts at Halton Hills Hydro Inc.

Primary Contact:

Name: _____ *Phone #:* _____

Address: _____

Email: _____

Secondary Contact (if applicable):

Name: _____ *Phone #:* _____

Address: _____

Email: _____

Contacts at _____ *(Customer)*

Primary Contact:

Name: _____ *Phone #:* _____

Address: _____

Email: _____

Secondary Contact (if applicable):

Name: _____ *Phone #:* _____

Address: _____

Email: _____

SCHEDULE G

Dispute Resolution (section 16.1)

- G.1 The Party claiming a dispute will provide written notice to the other Party. The Parties will make reasonable efforts through or by their respective senior executives to resolve any dispute within sixty days of receipt of such notice.
- G.2 If a dispute is settled by the senior executives of the Parties, the Parties shall prepare and execute minutes setting forth the terms of the settlement. Such terms shall bind the Parties. The subject-matter of the dispute shall not thereafter be the subject of any civil or other proceeding, other than in relation to the enforcement of the terms of the settlement. If a Party fails to comply with the terms of settlement, the other Party may submit the matter to arbitration under section G.3. A copy of the minutes referred to in this section from which all confidential information has been expunged shall be made available to the public by the Distributor upon request.
- G.3 If the senior executives of the Parties cannot resolve the dispute within the time period set out in section G.1 or such longer or shorter period as the Parties may agree, either Party may submit the dispute to binding arbitration under sections G.4 to G.8 by notice to the other Party.
- G.4 The Parties shall use good faith efforts to appoint a single arbitrator for purposes of the arbitration of the dispute. If the Parties fail to agree upon a single arbitrator within ten working days of the date of the notice referred to in section G.3, each Party shall within five working days thereafter choose one arbitrator. The two arbitrators so chosen shall within fifteen working days select a third arbitrator.
- G.5 Where a Party has failed to choose an arbitrator under section G.4 within the time allowed, the other Party may apply to a court to appoint a single arbitrator to resolve the dispute.
- G.6 A person may be appointed as an arbitrator if that person:
- (a) is independent of the Parties;
 - (b) has no current or past substantial business or financial relationship with either Party, except for prior arbitration; and
 - (c) is qualified by education or experience to resolve the dispute.
- G.7 The arbitrator(s) shall provide each of the Parties with an opportunity to be heard orally and/or in writing, as may be appropriate to the nature of the dispute.
- G.8 The *Arbitration Act, 1991* (Ontario) shall apply to an arbitration conducted under this Schedule G.
- G.9 The decision of the arbitrator(s) shall be final and binding on the Parties and may be enforced in accordance with the provisions of the *Arbitration Act, 1991* (Ontario). The Party against which the decision is enforced shall bear all costs and expenses reasonably incurred by the other Party in enforcing the decision.
- G.10 A copy of the decision of the arbitrator(s) from which any confidential information has been expunged shall be made available to the public by the Distributor upon request.
- G.11 Subject to section G.12, each Party shall be responsible for its own costs and expenses incurred in the arbitration of a dispute and for the costs and expenses of the

arbitrator(s) if appointed to resolve the dispute.

- G.12 The arbitrator(s) may, if the arbitrator(s) consider it just and reasonable to do so, make an award of costs against or in favour of a Party to the dispute. Such an award of costs may relate to either or both the costs and expenses of the arbitrator(s) and the costs and expenses of the Parties to the dispute.
- G.13 If a dispute is settled by the Parties during the course of an arbitration, the Parties shall prepare and execute minutes setting forth the terms of the settlement. Such terms shall bind the Parties, and either Party may request that the arbitrator(s) record the settlement in the form of an award under section 36 of the *Arbitration Act, 1991* (Ontario). The subject-matter of the dispute shall not thereafter be the subject of any civil or other proceeding, other than in relation to the enforcement of the terms of the settlement.
- G.14 If a Party fails to comply with the terms of settlement referred to in section G.13, the other Party may submit the matter to arbitration under section G.3 if the settlement has not been recorded in the form of an award under section 36 of the *Arbitration Act, 1991* (Ontario).
- G.15. A copy of the minutes referred to in section G.13 from which all confidential information has been expunged shall be made available to the public by the Distributor upon request.
- G.16 The Parties may not, by means of the settlement of a dispute under section G.2 or section G.13, agree to terms or conditions that are inconsistent with or contrary to the Code or this Agreement.

SCHEDULE H

Provisions Applicable if Facility Financed by a Lender (sections 19.3, 20.3 and 21.1)

- H.1 For the purposes of this Schedule, "lender" means a bank or other entity whose principal business is that of a financial institution and that is financing or refinancing the Facility.
- H.2 Where notice of a Default has been served on the Customer under section 19.3, an agent or trustee for and on behalf of a lender ("Security Trustee") or a receiver appointed by the Security Trustee ("Receiver") shall upon notice to the Distributor be entitled (but not obligated) to exercise all of the rights and obligations of the Customer under this Agreement and shall be entitled to remedy the Default specified in the notice within the applicable cure period referred to in section 19.4. The Distributor shall accept performance of the Customer's obligations under this Agreement by the Security Trustee or Receiver in lieu of the Customer's performance of such obligations, and will not exercise any right to terminate this Agreement under section 19.3 due to a Default if the Security Trustee, its nominee or transferee, or the Receiver acknowledges its intention to be bound by the terms of this Agreement and such acknowledgment is received within 30 days of the date of receipt by the Customer of the notice of Default.
- H.3 The Customer may, without the prior written consent of the Distributor, assign by way of security only all or any part of its rights or obligations under this Agreement to a lender. The Customer shall promptly notify the Distributor upon making any such assignment.
- H.4 The Customer may disclose confidential information of the Distributor to a lender or a prospective lender.

Appendix 9

Connection Impact Assessment Study Agreement

{Name of Project} Generating Station

{Name of Customer} (the "Customer") has requested and Halton Hills Hydro Inc. ("HHH") has agreed to perform the Work described below to determine the feasibility and impact of the Proposed Project defined below and to undertake the Work (as defined in the Scope of Work attached hereto as Schedule "A"), and under the Standard Terms and Conditions of Halton Hills Hydro's Guidelines for Applicants Connecting Distributed Generation and as stated below all forming a part hereof (the "Agreement") dated _____.

Proposed Project

The Proposed Project is the connection of **{Name of Project}** (the "Generation Facility") to HHH's distribution system at **{Station Name}** DS on **{Feeder Name}** and/ or which is connected to Hydro One's transmission system at **{Station Name}** TS.

Information Requirements

The Customer shall provide HHH with the following:

1. site location map(s) with suitable details of the **Generation Facility**, line routing and the proposed connection to HHH's facilities;
2. two sets of single line diagrams showing the line conductor sizes and distances from HHH's **{Station Name}** DS (the "Distribution Station) or TS (the "Transmission Station") to the Generation Facility interface transformer;
3. two sets of technical descriptions of the operating philosophy of the electrical equipment, and the protection and control philosophy of the Customer's Facilities that could affect HHH's distribution system;
4. A completed Generator Connection Assessment Review Form.

Submitted information must be signed and sealed by a Professional Engineer registered with the Professional Engineers of Ontario.

Completion Date:

Subject to OEB DSC 6.2.12 as applying to an applicant proposing to connect a small embedded generation facility HHH shall complete the Work, by no later than 60 days (where no system expansion is required) or 90 days (where a reinforcement and/ or system expansion is required by HHHI and/ or the upstream transmitter) after the latter of:

- (a) the Customer executing this Agreement;
- (b) the Customer paying HHH the amount specified below in (b) under the heading "Costs";
- (c) the Customer providing the information described above under the heading "Information Requirements".

Subject to OEB DSC 6.2.13 HHH shall complete the Work within 60 days of the receipt of the application in the case of a proposal to connect a mid-sized embedded generation facility or 90 days of the receipt of the application in the case of a proposal to connect a large embedded generation facility after the latter of:

- (a) the Customer executing this Agreement;
- (b) the Customer paying HHH the amount specified below in (b) under the heading “Costs”;
- (c) the Customer providing the information described above under the heading “Information Requirements”.

If at any time after the latter of the above HHH is unable to complete the Work within the applicable timeframe, HHH will inform the customer in writing that an extension is required to complete the Work and provide an estimated timeframe for completion of the Work.

HHH requires that the information requested from the applicant to complete the CIA be submitted as soon as possible. Delays in receiving information from the applicant may result in the CIA completion date not being met for which HHH is not liable.

Where a Connection Impact Assessment is required to be performed by another distributor in addition to that performed by HHH, HHH shall apply to that distributor for a Connection Impact Assessment. The applicant shall be responsible for any costs incurred by HHH in applying to that distributor for a Connection Impact Assessment. Such costs may or may not be included in the estimate provided by HHH for its Connection Impact Assessment as detailed in “Costs (a)” of this Agreement. If such is the case, completion and return of the Connection Impact Assessment may be dependant on the other distributors timing.

Impact of Subsequent Changes to the Information Provided by Customer

Should the Customer make any changes to the information provided by the Customer as described above under the heading “Information Requirements” after HHH has commenced the Work and those changes:

- (i) result in an increase in the cost of HHH performing the Work above the payment contemplated below under the heading “Costs”, the Customer shall make such further payment as may be required by HHH in the time specified by HHH; and
- (ii) otherwise affect any other provision of this Agreement, such as the time required for completion of the Work, the parties shall negotiate and agree upon the required amendments to this Agreement and HHH shall be under no obligation to resume performance of the Work until such time as the parties agree on such amendments.

Costs:

- (a) The Customer shall pay HHH's Actual Cost of performing the Work which amount is estimated to be:
\$ [REDACTED] (HHH CIA) + \$ [REDACTED] (Upstream/ Downstream LDC CIA) = \$ [REDACTED] (Total plus applicable Taxes)
- (b) The Customer agrees to pay HHH \$ [REDACTED] (plus applicable Taxes) by no later than 30 days after the date first written above towards the Actual Cost of the Work.
- (c) Within 90 days after the completion of the Work, HHH shall provide the Customer with a final invoice or credit memorandum which shall indicate whether the amounts already paid by the Customer exceed or are less than the Actual Cost of the Work. Any difference between the Actual Cost (plus applicable Taxes) and the amount already paid by the Customer shall be paid within 30 days after the rendering of the said final invoice or credit memorandum, by HHH to the Customer, if the amount already paid by the Customer exceeds the Actual Cost (plus applicable Taxes), or by the Customer to HHH, if the amount already paid by the Customer is less than the Actual Cost (plus applicable Taxes).

◇

HST Registration Information

The HST registration number for HHH is { [redacted] } and the HST registration number for the Customer is [Insert Number].

IN WITNESS WHEREOF, the parties hereto have caused this Agreement to be executed by the signatures of their proper officers, as of the day and year first written above.

HALTON HILLS HYDRO INC.,

Scott Knapman

Title: President & C.E.O.

I have the authority to bind the corporation

{Name of Customer}

Print: _____

Signature: _____

Title:

I have the authority to bind the corporation

SCHEDULE “A”: **Scope of Work - Connection Impact Assessment**

HHH will perform and provide the Customer with a Connection Impact Assessment to determine the feasibility of the Proposed Project by reviewing the impact of the Proposed Project on HHH’s distribution system.

HHH will make an application to Hydro One, the upstream transmitter, for their Connection Impact Assessment and shall describe any modification, telemetry, commissioning, or other requirements as deemed necessary within HHH’s Connection Impact Assessment. Timing for completion of HHHI’s CIA is dependent on receiving Hydro One’s CIA within the prescribed timeframes discussed herein.

HHH will advise the Customer of specific requirements, for each of the alternative connections that are identified by the Connection Impact Assessment.

HHH will describe the necessary modifications to HHH’s distribution system facilities based on HHH’s review of the Proposed Project in order to permit the connection of the Proposed Project.

◊

Appendix 10

Regulatory and Industry Contacts

Appendix 10

Regulatory and Industry Contacts

Halton Hills Hydro Inc.

43 Alice Street

Acton, Ontario

L7J 2A9

Phone: (519) 853-3700

(905) 453-2222

Fax: (519) 853-5168

Website: www.haltonhillshydro.com

Hydro One (Corporate)

483 Bay Street

15th Floor Reception

Toronto, Ontario

M5G 2P5

Website: www.hydroone.com

Ministry of Energy

900 Bay Street, 4th Floor

Hearst Block

Toronto, Ontario

M7A 2E1

Phone: 1-877-818-2900

Website: www.energy.gov.on.ca

Electrical Safety Authority

155A Matheson Blvd. West

Suite 200

Mississauga, Ontario

L5R 3L5

Phone: 1-877-421-2228

Website: www.esasafe.com

Independent Electricity System Operator

Suite 1600

1200 Adelaide Street West

Toronto, Ontario

M5H 1T1

Phone: 416-967-7474

Website: <http://www.ieso.ca/>

<http://fit.powerauthority.on.ca/>

Ontario Energy Board

P.O. Box 2319

2300 Yonge Street

Toronto, Ontario, Canada

M4P 1E4

Phone: 1-877-632-2727

Website: www.oeb.gov.on.ca

Canadian Standards Association

5060 Spectrum Way

Mississauga, Ontario

L4W 5N6

CANADA

Phone: 1-800-463-6727

Website: www.csa.ca

Canadian Wind Energy Association

Suite 320, 220 Laurier Avenue West

Ottawa, Ontario

Canada K1P 5Z9

Phone: 613-234-8716 or 1-800-922-6932

Website: www.canwea.ca

Canadian Solar Industries Association

CanSIA, 208 - 2378 Holly Lane,

Ottawa, ON,

K1V 7P1

Website: www.cansia.ca